

OPERATOR'S MANUAL

Pro Z Series 500/700/900 Steering Wheel

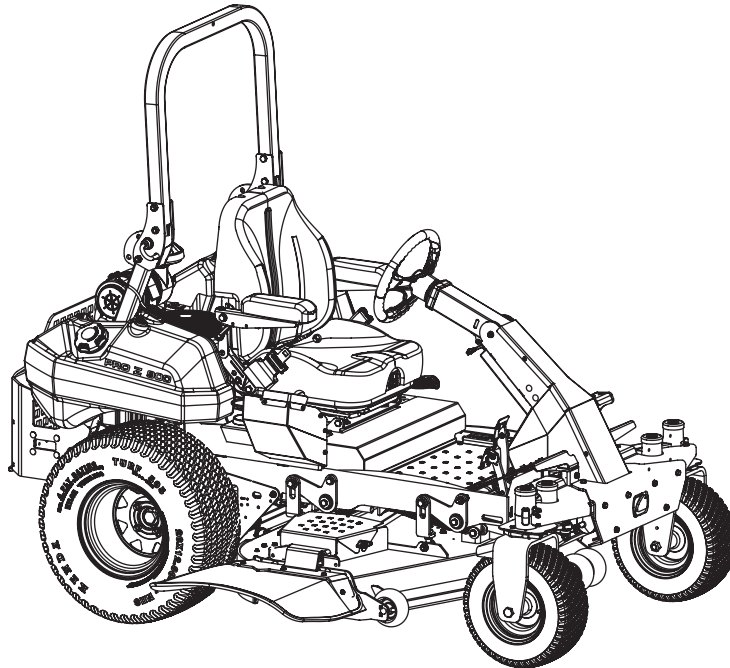

Table of Contents

<i>Safe Operation Practices</i>	2	<i>Replacement Parts</i>	27
<i>Assembly & Set-Up</i>	8	<i>Attachments & Accessories</i>	27
<i>Controls & Operation</i>	12	<i>Warranties</i>	29
<i>Product Care</i>	18		

⚠ WARNING

**READ AND FOLLOW ALL SAFETY RULES AND INSTRUCTIONS IN THIS MANUAL
BEFORE ATTEMPTING TO OPERATE THIS MACHINE.
FAILURE TO COMPLY WITH THESE INSTRUCTIONS MAY RESULT IN PERSONAL INJURY.**

NOTE: This Operator's Manual covers several models. Features may vary by model. Not all features in this manual are applicable to all models and the model depicted may differ from yours.



⚠ WARNING

⚠ This symbol points out important safety instructions which, if not followed, could endanger the personal safety and/or property of yourself and others. Read and follow all instructions in this manual before attempting to operate this machine. Failure to comply with these instructions may result in personal injury. When you see this symbol. **HEED ITS WARNING!**

⚠ WARNING

California Proposition 65

Engine Exhaust, some of its constituents, and certain vehicle components contain or emit chemicals known to the State of California to cause cancer and birth defects or other reproductive harm. Battery posts, terminals, and related accessories contain lead and lead compounds, chemicals known to the State of California to cause cancer and reproductive harm. Wash hands after handling.

⚠ DANGER

This machine was built to be operated according to the safe operation practices in this manual. As with any type of power equipment, carelessness, or error on the part of the operator can result in serious injury. This machine is capable of amputating hands and feet and throwing objects. Failure to observe the following safety instructions could result in serious injury or death.

Training

1. Read the Operator's Manual and other training material. If the operator(s) or mechanic(s) cannot read English it is the owner's responsibility to explain this material to them.
2. Become familiar with the safe operation of the machine, operator controls, and safety signs.
3. All operators and mechanics should be trained to operate or service the equipment. The owner is responsible for training them.
4. Never let children under the age of 16 or untrained people operate or service the equipment. Local regulations may further restrict the age of the operator.
5. The owner/operator can prevent and is responsible for accidents or injuries occurring to them, other people, or property.

General Operation

1. Read, understand, and follow all instructions on the machine and in the manual(s) before attempting to assemble and operate. Keep this manual in a safe place for future and regular reference by each operator and for ordering replacement parts.
2. Be familiar with all controls and their proper operation. Know how to stop the machine and disengage the controls quickly.
3. Do not allow anyone to operate or maintain this machine who has not read the manual. Never permit children under the age of 16 to operate this machine.
4. Do not remove any shields, guards, labels, or safety devices. If a shield, guard, label, or safety device is damaged or does not function, repair or replace it before operating the machine.
5. To help avoid blade contact or a thrown object injury, keep bystanders, helpers, children, and pets at least 75 feet (23 meters) from the machine while it is in operation. Stop machine if anyone enters the area.
6. Thoroughly inspect the area where the equipment is to be used. Remove all stones, sticks, wire, bones, toys, and other foreign objects that could be picked up and thrown by the blade(s). Thrown objects can cause serious personal injury.

7. Evaluate the terrain to determine what accessories and attachments are needed to properly and safely perform the job. Only use accessories and attachments approved by the machine manufacturer.
8. Plan your mowing pattern to avoid discharge of material toward roads, sidewalks, bystanders, and the like. Also, avoid discharging material against a wall or obstruction which may cause discharged material to ricochet back toward the operator.
9. Always wear appropriate clothing and personal protective equipment (e.g. safety glasses, long pants, gloves, hearing protection, safety shoes, hard hat) when operating or maintaining this machine. Long hair, loose fitting clothing, or jewelry may get entangled in moving parts. Follow all federal, state, and local guidelines regarding the use of personal protective equipment.
10. For extended use of this product, hearing protection is recommended.
11. Be aware of the mower and attachment discharge direction and do not point it at anyone. Do not operate the mower without the discharge cover or entire grass catcher in its proper place.
12. Do not put hands or feet near rotating parts or under the cutting deck. Contact with the blade(s) can amputate hands and feet.
13. A missing or damaged discharge cover can cause blade contact or thrown object injuries.
14. Stop the blade(s) when crossing gravel drives, walks, or roads and while not cutting grass.
15. Watch for traffic when operating near or crossing roadways. This machine is not intended for use on any public roadway.
16. Do not operate the machine while under the influence of alcohol or drugs.
17. Mow only in daylight or good artificial light.
18. Never carry passengers.
19. Back up slowly. Always look down and behind before and while backing to avoid a back-over accident.
20. Slow down before turning. Operate the machine smoothly. Avoid erratic operation and excessive speed. Be aware of your direction of travel to avoid accidents.
21. Disengage blade(s), set parking brake, stop engine, and wait until the blade(s) come to a complete stop before removing grass catcher, emptying grass, unclogging chute, removing any grass or debris, or making any adjustments.
22. Never leave a running machine unattended. Always stop on level ground, turn off blade(s), place drive speed control levers/pedals in neutral, set parking brake, stop engine and remove key before leaving the operator position.
23. Use extra care when loading or unloading the machine on a trailer or truck. The machine should not be driven on unstable, unsecured, or inadequate ramps because the machine could tip over causing serious personal injury.
24. Check overhead clearances carefully before driving under low hanging tree branches, wires, door openings, etc., where the operator and/or ROPS may be struck which could result in serious injury and/or machine tip over.
25. Muffler and engine become hot and can cause a burn. Do not touch.
26. Disengage the blades, set the parking brake to the 'on' position and make sure the speed control levers/pedals are in the neutral position before attempting to start the engine. Only start the engine from the operator's position.
27. Do not attempt to mow unusually tall, dry grass (e.g., pasture) or piles of dry leaves. Dry grass or leaves may contact the engine exhaust and/or build up on the mower deck presenting a potential fire hazard.
28. Do not stop or park the machine over dry leaves, grass, debris, or other combustible material.
29. Never attempt to operate the machine without the mowing deck attached; the machine could tip over.
30. Keep the machine and especially the engine exhaust system and hydraulic components clean and free of grease, grass, and leaves to reduce the potential for overheating and fire.
31. Allow the machine to cool at least 5 minutes before storing.

32. Use only accessories and attachments approved for this machine by the machine manufacturer. Read, understand, and follow all instructions provided with the approved accessory or attachment.
33. Data indicates that operators, age 65 years and above, are involved in a large percentage of riding mower-related injuries. Operators should evaluate their ability to operate this machine safely enough to protect themselves and others from serious injury.
34. Do not operate or start machine if there are fuel or oil leaks; repair immediately.
35. When looking for oil leaks, never run your hand over hydraulic hoses, lines or fittings. Never tighten or adjust hydraulic hoses, lines, or fittings while the system is under pressure. If high-pressure oil penetrates the skin seek immediate medical attention or gangrene and permanent damage may result. Do not check for hydraulic leaks with your hands, use paper or cardboard instead. Wear gloves and safety glasses when checking for leaks.
36. Do not operate machines that have been damaged or have not been properly maintained. If the machine has been damaged, then have it repaired.
37. When operating this machine in the forward direction, do not allow the speed control levers/pedals to return to the neutral position on their own. Always operate them smoothly and avoid any sudden movements of the levers/pedals when starting or stopping.
38. If situations occur which are not covered in this manual use care and good judgement. Contact your customer service representative for assistance.

Slope Operation

Slopes are a major factor related to loss of control and tip-over accidents that can result in severe injury or death. All slopes require extra caution. If you cannot back up the slope or if you feel uneasy on it, do not mow it or drive on the slope.

For your safety, use the slope gauge included as part of this manual to measure slopes before operating this machine on a sloped or hilly area. If the slope is greater than 20° (35%) as shown on the slope gauge, do not operate this machine on that area or serious injury could result.

Do:

1. Mow across slopes, not up and down. Exercise extreme caution when changing direction on slopes.
2. Watch for holes, ruts, bumps, rocks, or other hidden objects. Uneven terrain could overturn the machine. Tall grass can hide obstacles.
3. Use slow speed. Choose a low enough speed so that you will not have to stop while on the slope. Avoid starting or stopping on a slope. If the tires are unable to maintain traction, disengage the blades and proceed slowly and carefully straight down the slope.

4. Keep all movements on the slopes slow and gradual. Do not make sudden changes in speed or direction. Rapid acceleration could cause the front of the machine to lift and rapidly flip over backwards, which could cause serious injury or death.
5. Follow the manufacturer's recommendations for wheel weights or counterweights to improve stability.
6. Use extra care with grass catchers or other attachments. These can change the stability of the machine.

Do Not:

1. Do not turn on slopes unless necessary; then turn slowly uphill and use extra care while turning.
2. Do not mow near drop-offs, ditches, or embankments. The machine could suddenly turn over if a wheel is over the edge of a cliff, ditch, or if an edge caves in.
3. Do not operate on slopes or near the edge of water such as a lake, pond, river, or stream where the machine could slip, tip or roll-over into the water.
4. Do not try to stabilize the machine by putting your foot on the ground.
5. Use extra care while operating tractor with grass catcher or other attachment(s). They can affect the stability of the tractor. Do not use grass catcher on slopes greater than 10° (17%).
6. Do not mow on wet grass. Reduced traction could cause sliding and/or loss of control.
7. Do not tow heavy pull behind attachments (e.g. loaded dump cart, lawn roller, etc.) on slopes greater than 5° (9%). When going downhill, the extra weight tends to push the machine and may cause loss of traction and loss of control (e.g. machine may speed up, braking and steering ability are reduced, attachment may jack-knife and cause machine to overturn).

Children

1. Tragic accidents can occur if the operator is not alert to the presence of children. Children are often attracted to the machine and the mowing activity. They do not understand the dangers. Never assume that children will remain where you last saw them.
 - a. Keep children out of the mowing area and in watchful care of a responsible adult other than the operator.
 - b. Be alert and turn machine off if a child enters the area.
 - c. Always look behind and down for small children. Use slow speed.
 - d. Never carry children, even with the blade(s) shut off. They may fall off and be seriously injured or interfere with safe machine operation.
 - e. Use extreme care when approaching blind corners, doorways, shrubs, trees, or other objects that may block your vision of a child who may run into the path of the machine.

- f. To avoid back-over accidents, always disengage blades before traveling in reverse.
 - g. Keep children away from hot or running engines. They can suffer burns from a hot muffler.
 - h. Remove key when machine is unattended to prevent unauthorized operation.
2. Never allow children under 16 years of age to operate this machine. Children 16 and over should read and understand the instructions and safe operation practices in this manual and on the machine and should be trained and supervised by an adult.

Towing

1. Do not tow heavy tow-behind attachments (e.g. loaded dump cart, lawn roller, etc.) on slopes greater than 5° (9%).
2. Tow only with a machine that has a hitch designed for towing. Do not attach towed equipment except at the hitch point.
3. Follow the manufacturer's recommendation for weight limits for towed equipment and towing on slopes.
4. Never allow children or others in or on towed equipment.
5. On slopes, the weight of the towed equipment may cause loss of traction and loss of control.
6. Travel slowly and allow extra distance to stop.
7. Make wide turns to avoid jack knifing.

Transporting Machines

1. This machine is not intended for use on public roads. Machines operated on public roads must comply with state & local ordinances, SAE J137, and ANSI/ASABE S279 (lighting and marking requirements).
2. Use care when loading or unloading machines onto trailers and trucks.
3. If ramps are used, they must be full width, stable, have an adequate capacity rating and be secured to the trailer or truck. Ramp angle should not exceed 20° (35%) and trailer or truck should be parked on level terrain.
4. Machines must be secured onto trailers and trucks with straps, chains, cables, ropes, or other means deemed adequate for that purpose. The front and rear of the machines must be secured to the trailer or truck in both the lateral and vertical directions.

Operator Protective System (OPS)

1. This machine is equipped with an Operator Protective System (OPS), which includes:
 - a. A Roll Over Protective Structure (ROPS) of the fixed or folding configuration.
 - b. Seat belt assembly with retractable function.

2. ROPS are structures designed to provide a crush-resistant space for the operator when properly seat-belted within the designated seating area of the machine in the event of a machine tip-over or roll-over. Folding ROPS shall be used in their fully upright and locked configurations except in those circumstances whereby they need to be momentarily folded-down to avoid contact with items such as tree limbs, clothes lines, guy wires, utility poles, buildings, etc. At other times and conditions, ROPS shall be in their fully upright and locked configurations.

▲ DANGER
Damaged ROPS must be replaced prior to operator use.

3. Seat belts shall be used and shall be properly fastened about the operator's waist at all times, except when the ROPS are:
 - a. Not properly installed and/or not properly secured onto the machine.
 - b. Damaged in such manner that their structural integrity has been compromised.
 - c. Not in their fully upright and locked position.
4. Seat belts are attached to the movable portion of the seat when suspension seats are utilized, and therefore the seat-mounting base must be secured to its pivot means and the pivot means latched to the frame of the machine. Seat belts are attached to the seat or the frame of the machine when non-suspension (standard) seats are provided, however, if a suspension kit is added to a seat, the seat belt must be attached to the movable portion of the seat or suspension mechanism, the seat-mounting base must be secured to its pivot means, and the pivot means be latched to the frame of the machine.

▲ DANGER
If ROPS are folded down or missing, seat belts shall not be fastened. Worn or damaged seat belt assemblies must be replaced prior to operator use.

5. A brush guard or canopy may deflect tree limbs, clothes lines, and other obstacles that otherwise could come in contact with the ROPS. Contact of ROPS and/or canopies by items such as tree limbs, clothes lines, guy wires, and buildings, could create hazardous conditions whereby the machine could experience a tip-over or roll-over. A canopy may provide protection for the operator from some environmental exposure (sunlight, rain, etc.).
6. The ROPS and seat belt are integral parts of this machine and should not be tampered with, modified in any manner, or removed.
7. Inspect the ROPS and seat belt assemblies on a regular basis for damage and improper operation. Replace all components that are damaged or are not functioning properly with authorized replacement parts.

8. The ROPS extends above and behind the operator position, and therefore the operator must be aware of potential contact of the ROPS with items such as trees, buildings, doorways, clothes lines, utility wires, etc., that could cause the machine to tip-over or rollover. Use caution in (or avoid) areas where the ROPS could come in contact with any structures, trees, etc.
9. Inspect the ROPS and seat belt assemblies on a regular basis for damage and improper operation. Replace all components that are damaged or are not functioning properly with authorized replacement parts.
10. Failure to use the seat belt properly could result in serious injury or death if an accidental overturn occurs. In order for the ROPS to be effective, the seat belt must be securely fastened around the operator at all times when the operator is on the machine. Contact with the ROPS during an overturn could cause serious injury or death.
11. The ROPS will not prevent machine from tip-overs or roll-overs.
12. Do not assume ROPS will protect you in a tip-over or roll-over. Injuries may still occur.

Hydraulic Devices & Systems

Hydraulic fluid escaping under pressure may have sufficient force to penetrate skin and cause serious injury. If foreign fluid is injected into the skin or eyes, seek immediate medical attention or gangrene and permanent damage may result.

▲ WARNING
Keep body and hands away from pinholes or nozzles that could inject hydraulic fluid under high pressure. Use paper or cardboard, not your hands, to search for leaks! Wear gloves and safety glasses.

Safely relieve all pressure in the system before performing any work on the system, and make sure that:

- The ignition switch is OFF.
- The key is removed.
- The engine spark plug wire(s) is removed.
- All connections to the negative terminal of the battery are removed.
- The park brake is set.
- All by-pass valves, if so equipped, are open.
- Hydraulic controls are actuated to release pressure on pumps, cylinders, etc. If "float" positions are available, they should be used.

After the above operations are completed, it should be safe to begin disconnecting the lines or components. It is still a good idea to cover the connection with a cloth shield and then gently loosen connections.

▲ WARNING
Make sure all hydraulic fluid connections are tight and all hydraulic hoses and lines are in good condition before applying pressure to the system.

Service

Safe Handling of Fuel

To avoid personal injury or property damage use extreme care in handling fuel. Fuel is extremely flammable and the vapors are explosive. Serious personal injury can occur when fuel is spilled on yourself or your clothes which can ignite. Wash your skin and change your clothes immediately.

- Use only approved containers.
- Never fill containers inside a vehicle or a truck or trailer bed with a carpeted or plastic liner. Always place containers on the ground away from your vehicle before fueling.
- When practical, remove machines from the truck or trailer and refuel it on the ground. If this is not possible, then refuel equipment on a trailer with a portable container rather than from a fuel dispenser nozzle.
- Keep nozzle in contact with the rim of the fuel tank or container opening at all times until fueling is complete. Do not use a nozzle lock-open device.
- Extinguish all cigarettes, cigars, pipes, and other sources of ignition.
- Never fuel machine indoors or near ignition sources.
- Never remove fuel cap or add fuel while the engine is hot or running. Allow engine to cool at least 5 minutes before refueling.
- Never over fill fuel tank. Fill tank to no more than 1/2 inch below bottom of filler neck to allow space for expansion.
- If necessary, use a funnel to avoid spillage.
- Replace fuel cap and tighten securely.
- If fuel is spilled, wipe off the engine and equipment. Wait 5 minutes before starting the engine.
- To reduce fire hazards, keep machine free of grass, leaves, or other debris build-up. Clean up oil and fuel spillage and remove any fuel soaked debris.
- Never store the machine or fuel container inside where there is an open flame, spark or pilot light as on a water heater, space heater, furnace, clothes dryer, or other gas appliance.

General Service

1. Never run an engine indoors or in a poorly ventilated area. Engine exhaust contains carbon monoxide, an odorless, and deadly gas.
2. Before cleaning, repairing, or inspecting, make certain the blade(s) and all moving parts have stopped. Disconnect the spark plug wires and remove the key from the ignition to prevent unintended starting.
3. Periodically check to make sure the blades come to a complete stop within approximately 7 seconds after operating the blade disengagement control. If the blades do not stop within this time frame, your machine should be serviced.
4. Never tamper with the safety interlock system or other safety devices.

5. Regularly check the safety interlock system for proper function, as described later in this manual. If the safety interlock system does not function properly, have your machine serviced.
6. Check brake operation frequently as it is subjected to wear during normal operation. Adjust and service as required.
7. Check the blade(s) and engine mounting bolts at frequent intervals for proper tightness. Also, visually inspect blade(s) for damage (e.g., excessive wear, bent, cracked). Replace the blade(s) with the original equipment manufacturer's (O.E.M.) blade(s) only, listed in this manual. Use of parts which do not meet the original equipment specifications may lead to improper performance and compromise safety!
8. Mower blades are sharp. Wrap the blade or wear gloves, and use extra caution when servicing them.
9. Keep all nuts, bolts, and screws tight to be sure the equipment is in safe working condition.
10. After striking a foreign object (or if abnormal vibration occurs), stop the blades and engine and thoroughly inspect the machine for any damage. Make necessary repairs before resuming operation.
11. Never attempt to make adjustments or repairs to the machine while the engine is running.

12. Grass catcher components and the discharge cover are subject to wear and damage which could expose moving parts or allow objects to be thrown. For safety protection, frequently check components and replace immediately with original equipment manufacturer's (O.E.M.) parts only, listed in this manual. Use of parts which do not meet the original equipment specifications may lead to improper performance and compromise safety!
13. Do not change the engine governor settings or over-speed the engine. The governor controls the maximum safe operating speed of the engine.
14. Maintain or replace safety and instruction labels, as necessary.
15. Observe proper disposal laws and regulations for gas, oil, etc. to protect the environment.

Do not modify engine

To avoid serious injury or death, do not modify engine in any way. Tampering with the governor setting can lead to a runaway engine and cause it to operate at unsafe speeds. Never tamper with factory setting of engine governor.

Notice Regarding Emissions

This machine is equipped with an engine that is certified to federal EPA emission standards for non-road engines and equipment, and where applicable to California Air Resources Board (CARB) emission standards. The engine owner's manual is supplied by the engine manufacturer, and provides additional information relating to the emission system, warranty, maintenance of the engine in accordance with EPA and/or CARB regulations. Making any unauthorized alterations or modifications to the engine, fuel, or venting systems may violate EPA and CARB regulations.

When required, models are equipped with low permeation fuel lines and fuel tanks for evaporative emission control. California models may also include a carbon canister. Please contact Customer Support for information regarding the evaporative emission control configuration for your model.

This machine is designed to run on regular, unleaded gasoline, 87 octane or higher. Never use gasoline containing methanol or gasoline containing more than 10% ethanol (i.e., E15 or E85 fuels) because the fuel system may be damaged.

Spark Arrestor

▲ WARNING
This machine is equipped with an internal combustion engine and should not be used on or near any unimproved forest-covered, brush-covered, or grass-covered land unless the engine's exhaust system is equipped with a spark arrestor meeting applicable local or state laws (if any).









If a spark arrestor is used, it should be maintained in effective working order by the operator. In the State of California the above is required by law (Section 4442 of the California Public Resources Code). Other states may have similar laws. Federal laws apply on federal lands.

A spark arrestor for the muffler is available through your nearest engine authorized service dealer or contact the service department, P.O. Box 361131 Cleveland, Ohio 44136-0019.

Safety Symbols

This page depicts and describes safety symbols that may appear on this product. Read, understand, and follow all instructions on the machine before attempting to assemble and operate.

Symbol	Description
	READ THE OPERATOR'S MANUAL(S) Read, understand, and follow all instructions in the manual(s) before attempting to assemble and operate.
	WARNING — ROTATING PARTS Do not put hands or feet near rotating parts or under the cutting deck. Contact with the blade(s) can amputate hands and feet.
	WARNING — THROWN OBJECTS This machine may pick up and throw objects which can cause serious personal injury.

Symbol	Description
	BYSTANDERS Keep bystanders, helpers, children, and pets at least 75 feet (23 meters) from the machine while it is in operation.
	DANGER — BACK-OVER To avoid back-over accidents, always disengage blades before traveling in reverse.
	WARNING — SLOPE OPERATION Do not operate this machine on a slope greater than 20° (35%).
	DANGER — ROTATING BLADES To reduce the risk of injury, keep hands and feet away. Do not operate unless discharge cover or grass catcher is in its proper place. If damaged, replace immediately.
	DANGER — SAFETY DEVICES Keep safety devices (guards, shields, switches, etc.) in place and working.
	WARNING — AVOID SERIOUS INJURY OR DEATH FROM ROLL OVER Keep roll bar in the raised upright position with your seat belt fastened. Lower roll bar and do not fasten seat belt in low clearance situations. Raise roll bar and fasten seat belt as soon as clearance permits. Do not drill, weld, or alter the roll bar in any way. Altering the roll bar could lead to serious injury or death.
	WARNING — AVOID TOWING RELATED INJURY Do not tow a load that exceeds 250 lbs (113 kg) rolling weight and never exceed 50 lbs (22 kg) tongue weight. Never allow children or others in or on towed equipment. Do not tow on slopes greater than 5° (9%). On slopes, the weight of the towed equipment may cause loss of traction, loss of control, and/or loss of the ability to stop. Travel slowly and allow extra distance to stop.
	WARNING — REMOVE SPARK PLUG CAP BEFORE SERVICING Before working on the machine, remove the spark-plug connector! Keep fingers and feet away from the blades! Always switch off the machine and remove the spark plug connector before adjusting, cleaning, or checking it.
	WARNING — AVOID FIRES Your tractor is designed to cut normal residential grass of a height no more than 10" (25 cm). Do not attempt to mow through unusually tall, dry grass (e.g., pasture) or piles of dry leaves. Allow tractor to cool at least 5 minutes before fueling or storing inside an enclosed garage or storage shed.

▲ WARNING

Your Responsibility — Restrict the use of this power machine to persons who read, understand, and follow the warnings and instructions in this manual and on the machine.

SAVE THESE INSTRUCTIONS!

Slope Gauge

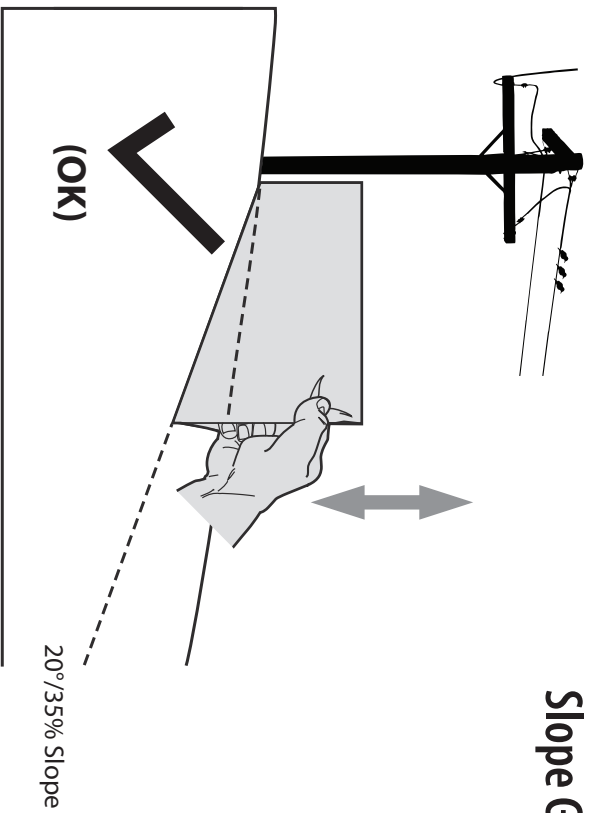

Figure 1

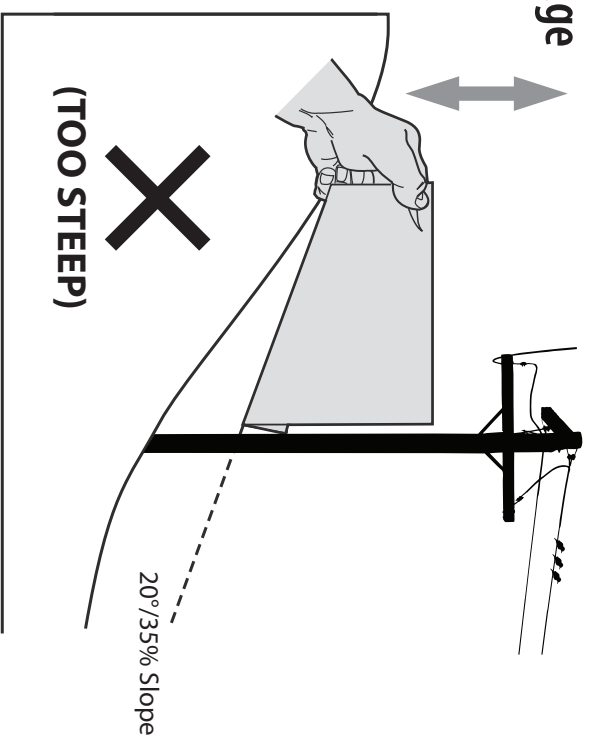
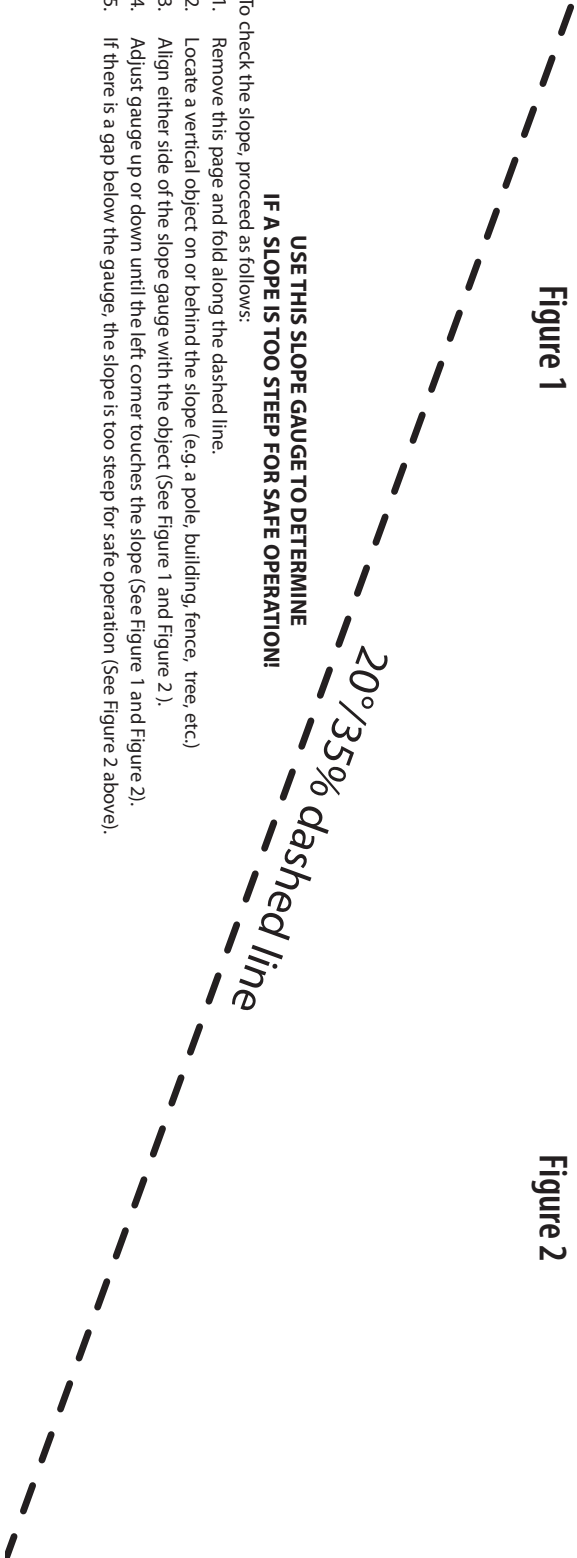

Figure 2

USE THIS SLOPE GAUGE TO DETERMINE IF A SLOPE IS TOO STEEP FOR SAFE OPERATION!

To check the slope, proceed as follows:

1. Remove this page and fold along the dashed line.
2. Locate a vertical object on or behind the slope (e.g. a pole, building, fence, tree, etc.)
3. Align either side of the slope gauge with the object (See Figure 1 and Figure 2).
4. Adjust gauge up or down until the left corner touches the slope (See Figure 1 and Figure 2).
5. If there is a gap below the gauge, the slope is too steep for safe operation (See Figure 2 above).



Use this page as a guide to determine slopes where you may not operate safely.

▲ WARNING

Do not operate your tractor on such slopes. Do not mow on inclines with a slope in excess of 20°/35%. A tractor could overturn and cause serious injury. Mow across slopes, not up and down.

Thank You

Thank you for purchasing this product. It was carefully engineered to provide excellent performance when properly operated and maintained.

Please read this entire manual prior to operating the equipment. It instructs you how to safely and easily set up, operate and maintain your machine. Please be sure that you, and any other persons who will operate the machine, carefully follow the recommended safety practices at all times. Failure to do so could result in personal injury or property damage.

All information in this manual is relative to the most recent product information available at the time. Review this manual frequently to familiarize yourself with the machine, its features and operation. Please be aware that this Operator's Manual may cover a range of product specifications for various models. Characteristics and features discussed and/or illustrated in this

manual may not be applicable to all models. We reserve the right to change product specifications, designs and equipment without notice and without incurring obligation.

If applicable, the power testing information used to establish the power rating of the engine equipped on this machine can be found at www.opei.org or the engine manufacturer's web site.

If you have any problems or questions concerning the machine, phone your local authorized service dealer or contact us directly. We want to ensure your complete satisfaction at all times.

Throughout this manual, all references to *right* and *left* side of the machine are observed from the operating position.

Contents of Carton

- Zero-Turn Tractor (1)
- Seat Mounting Hardware (1)
- Engine Operator's Manual (1)
- Steering Wheel (1)
- Battery Installation Hardware (1)
- Seat Tilt Knob Assembly & Hardware Pack (1)
- Tractor Operator's Manual (1)

Note: This Operator's Manual covers several models. Tractor features may vary by model. Not all features in this manual are applicable to all tractor models and the tractor depicted may differ from yours.

Note: All references in this manual to the left or right side and front or back of the machine are from the operating position only. Exceptions, if any, will be specified.

Tractor Preparation

TOOLS NEEDED: Safety glasses, leather gloves, wire cutters

1. Remove the upper crating material from the shipping pallet, and cut any bands or tie straps securing the tractor to the pallet.
2. Use the deck lift pedal (a) to raise the deck to its highest position and secure in place with the clevis pin (b) attached to the tractor. See Figure 2-1.

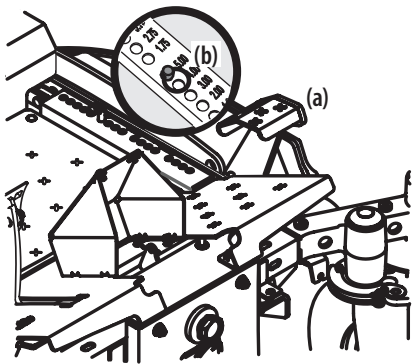

Figure 2-1

3. The two hydrostatic transmissions are equipped with a bypass valve that will allow you to manually move the tractor short distances.
4. Engage the transmission bypass valves by pulling the bypass lever (a) outward then upward and all the way back. See Figure 2-2.

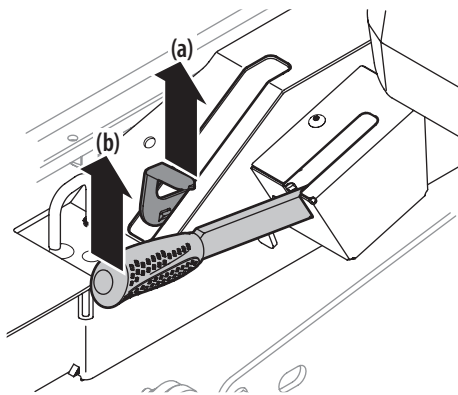

Figure 2-2

⚠ WARNING

Do not tow the tractor, even with the bypass valves engaged. Serious transmission damage will result from doing so.

5. Carefully roll the tractor off the shipping pallet.
6. To release the bypass lever (a), push the lever forward. See Figure 2-2.
7. To engage the parking brake, pull back completely on the parking brake lever (b). See Figure 2-2.
8. Cut any wire ties holding the chute deflector up and discard any packing material.

Roll Over Protective Structure (ROPS)

1. Pull slightly up on the upper ROPS to relieve any tension on the locking pin (a) and rotate the locking pin (a) from the LOCKED (b) position into the ADJUSTMENT (c) position. See Figure 2-3. Repeat the procedure for the locking pin on the opposite side.

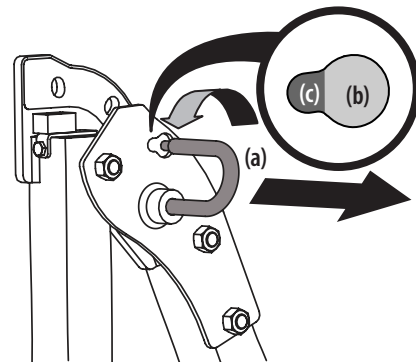

Figure 2-3

2. When both locking pins are secured in the ADJUSTMENT position, slowly lift and rotate the upper ROPS from the TRANSPORT (a) position, past the TRANSPORT WITH BAGGER (b) position and into the OPERATION (c) position. See Figure 2-4.

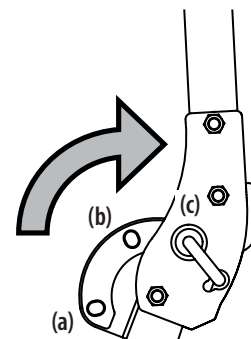

Figure 2-4

3. Rotate both locking pins into the LOCKED position. Move the upper ROPS slightly until the locking pins are fully engaged in the LOCKED position.

Steering Wheel Column

The steering wheel column is tilted all the way down for shipping purposes. To adjust the column pull up on the steering column adjustment lever (a) and move the steering column up into the desired position. Release the steering column adjustment lever (a) to secure the steering column in the desired position. See Figure 2-5.

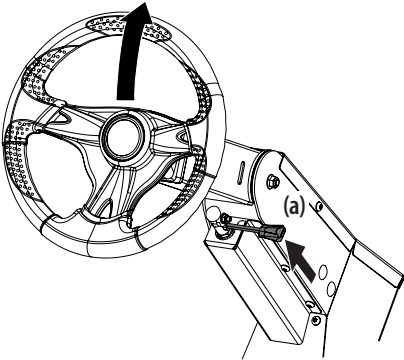

Figure 2-5

Steering Wheel

IMPORTANT! Do not use impact tools to install or remove the steering wheel. Doing so may cause damage to critical power steering components.

1. Remove the hardware for attaching the steering wheel from beneath the steering wheel cap (a). Carefully pry off the steering wheel cap (a) to remove the hardware. See Figure 2-6.
2. With the wheels of the machine pointing straight forward, place the steering wheel (b) over the steering shaft. See Figure 2-6.
3. Place the Belleville washer (c) over the steering wheel (b) and secure with the hex lock screw (d). See Figure 2-6.

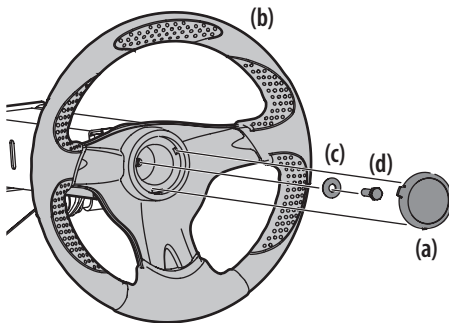

Figure 2-6

4. Place the steering wheel cover over the center of the steering wheel and push downward until it "clicks" into place.

Operator's Seat

1. Remove the two flange lock nuts (b) and shoulder bolts (a) from the manual bag. See Figure 2-7.

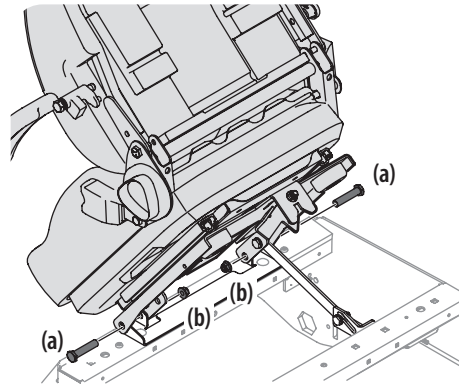

Figure 2-7

2. Place the seat into position and secure the seat into place with the hardware as shown in Figure 2-7.
3. Remove the shoulder screw (a) and flange lock nut (b) from manual bag and install the seat lockout bracket (c) as shown in Figure 2-8.

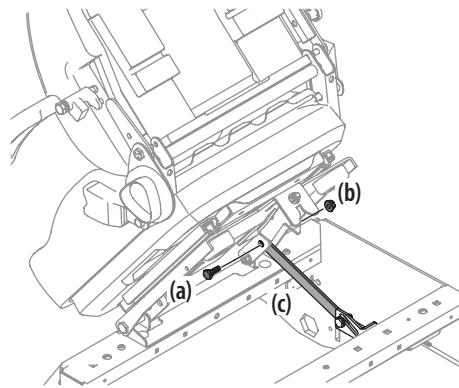

Figure 2-8

4. Insert the wiring harness (a) into the bottom of the seat as shown in Figure 2-9.

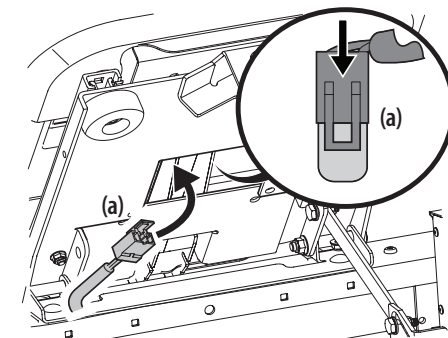

Figure 2-9

Note: When the wiring harness (a) is connected, be sure to push the excess wire from the wire harness (a) into the seat box hole before continuing. See Figure 2-9.

5. Remove the screw (a) securing the recliner plate in the seat back position. See Figure 2-10.

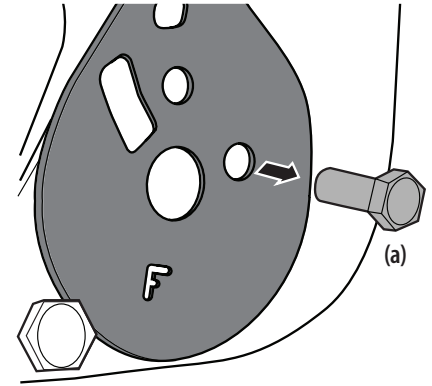

Figure 2-10

6. Tilt the seat forward into the full forward position. Replace the recliner plate with the clinch-stud (a) and the recliner pin (b) passing through the recliner plate in the locations shown in Figure 2-11.

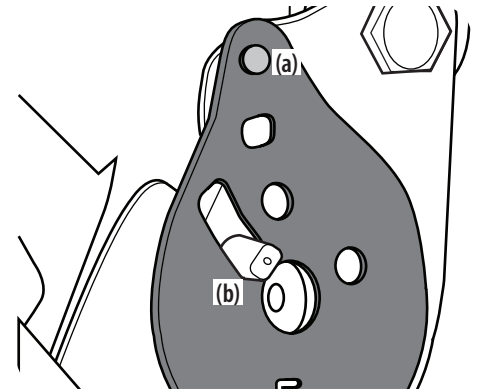

Figure 2-11

7. Remove the seat tilt knob assembly from the bag and install as shown in Figure 2-12.

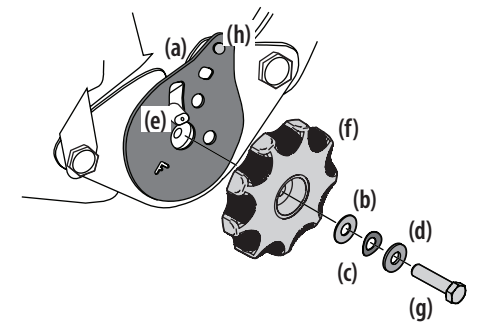

Figure 2-12

Note: Be sure to orient the recliner plate (a) and install the plastic washer (b), spring washer (c) and metal washer (d) as shown in Figure 2-12. The plastic washer is on the inside.

8. Slide the recliner bearing plate (a) onto the recliner pin (e). Refer to Figure 2-12.

- Then align the spiral (a) on the inside of the recliner knob with the recliner pin. Make sure the hub on the back of the recliner sits properly into the large holes of the side plate. See Figure 2-13.

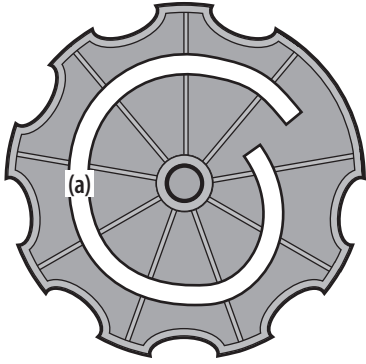

Figure 2-13

- Use a wrench to hand tighten the hex screw (g) until the recliner knob (f) is difficult to turn. Refer to Figure 2-12.
- Note:** Do not use power tools to install.
- Gradually loosen the hex screw (g) until the recliner knob moves freely. Do not loosen the hex screw (g) more than one full turn. Refer to Figure 2-12.
 - Securely install the 1/4" nut onto the clinch-stud (h) and rotate the recliner knob to check the operation of the seat. Refer to Figure 2-12.

Seat Adjustment

Proper steering column and seat adjustment will result in the following (to adjust the seat see below):

In the neutral position with hands on the steering wheel,

- Operator's upper arms should be relaxed and approximately vertical.
- Operator's forearms should be approximately horizontal.
- Operator's back should stay in contact with the seat back.
- Steering column should not contact operator's legs.

Check the results of any adjustments to the conditions described above. Repeat any adjustment procedures as required until all conditions are met.

This machine is equipped with an adjustable seat, which includes a retractable seat belt assembly and an Operator Presence Sensor (OPS). The OPS, in the form of a switch, is integrated into the seat bottom and is connected to the machine electrical system. The OPS must be connected to the electrical wiring harness.

The seat can be adjusted forward and backward, the armrests can be adjusted up and down (700 and 900 series), the mechanical suspension mechanism weight/ride adjustment controls can be adjusted for weights between 125- and 275-pounds (500 and 700 series) or air ride adjustment (900 series), a lumbar support can be adjusted and the seat can tilt forward and backward.

Note: The seat base must be secured by the latch, otherwise, the seat assembly could tilt forward.

To move the seat forward or back, locate the seat adjustment rod under the seat. Push the rod to the left, slide the seat forward or back into the desired position and release the rod when the seat is in the desired position. See Figure 2-14.

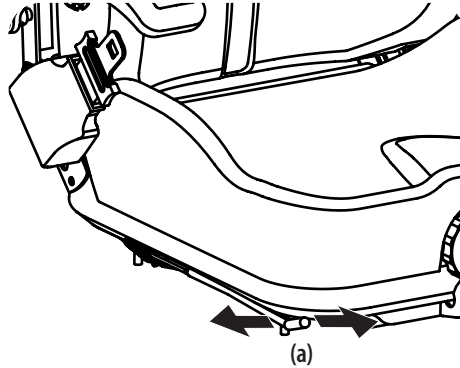

Figure 2-14

The seat tilt is controlled by the knob on the left of the seat. Turn the knob rearward to tilt the seat back, turn the knob forward to tilt the seat forward. See Figure 2-15.

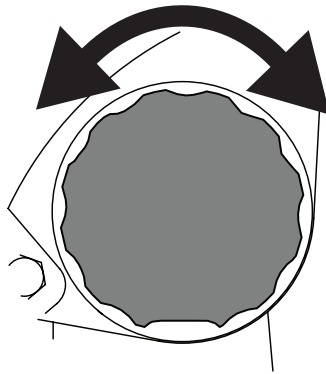

Figure 2-15

The mechanical suspension mechanism (500 and 700 series) incorporates weight/ride adjustment controls for operators in the 125 to 275 lb weight range. Turn the knob on the front of the seat clockwise to increase the weight capacity and counter-clockwise to decrease. See Figure 2-16.

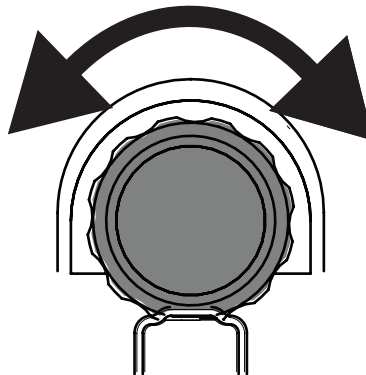

Figure 2-16

To vary the lumbar support (700 and 900 series) move the lever on the right of the seat up and down. See Figure 2-17.

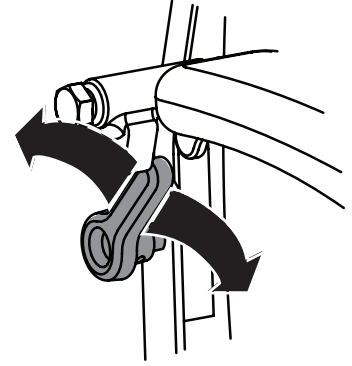

Figure 2-17

To adjust the height of the arm rests (700 and 900 series), lift the arm rest and rotate the knob under the arm rest right or left to increase or decrease the height. See Figure 2-18.

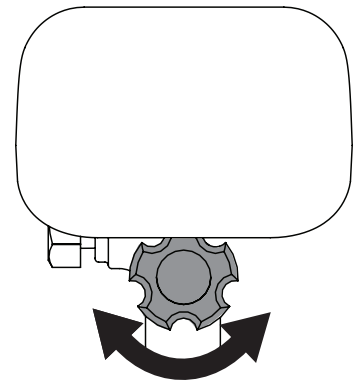

Figure 2-18

The air ride (900 series) can be adjusted up or down using the height adjustment lever on the front of the seat. Press the lever to the left (+) to raise the height of seat and to the right (-) to lower the height of the seat. See Figure 2-19.

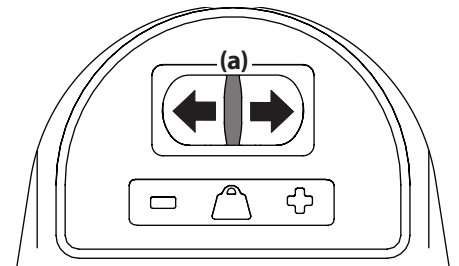

Figure 2-19

Checking Tire Pressure

▲ WARNING

Maximum tire pressure under any circumstances is 12 psi on rear tires and 25 psi on front tires. Equal tire pressure should be maintained at all times.

Inflation Pressure

Rear Tires — 10-12 psi max

Front Tires — 20-25 psi max

The tires on your tractor may be over-inflated for shipping purposes. Reduce the tire pressure before operating the tractor. Recommended operating tire pressure is 10-12 psi on rear tires and 20-25 psi on front tires.

Lubrication & Grease Points

Before operating the tractor, refer to the Product Care section of this manual to check the lubrication and grease points. Grease and lubricate if necessary.

Connecting the Battery Cables

▲ WARNING

California **PROPOSITION 65**: Battery posts, terminals, and related accessories contain lead and lead compounds, chemicals known to the State of California to cause cancer and reproductive harm. Wash hands after handling.

▲ CAUTION

When attaching battery cables, always connect the POSITIVE (Red) wire to its terminal first, followed by the NEGATIVE (Black) wire.

For shipping reasons, both battery cables on your equipment may have been left disconnected from the terminals at the factory. To connect the battery cables, proceed as follows:

1. Using the lever on the back of the seat frame, lift up on the lever and tilt the seat forward locking it in place with the seat prop. Remove the bolts and hex nuts from the manual bag.

Note: The positive battery terminal is marked POS. (+) (a). The negative battery terminal is marked NEG. (-) (b). See Figure 2-20.

Note: If the positive battery cable (c) is already attached, skip ahead to Step 6. See Figure 2-20.

2. Locate the cables routed through the conduit along the inward facing side of the battery and separate the positive and negative groupings (each group will be zip-tied together).
3. Slide the red boot (d), if present, back along the positive cable grouping. See Figure 2-20.
4. Attach the positive cable grouping (c) and positive cable for the 12V outlet (if equipped) to the positive battery terminal (a) with the bolt (e) and sems nut (f). See Figure 2-20.

Note: Place the thickest cable closest to the battery terminal.

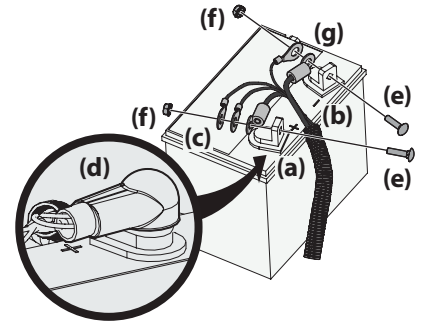

Figure 2-20

5. Position the red boot (d) over the positive battery terminal (a) to insulate it and help protect it from corrosion. See Figure 2-20.
6. Attach the negative cable grouping (g) and negative cable for the 12V outlet (if equipped) to the negative battery terminal (b) with the bolt (e) and sems nut (f). See Figure 2-20.

Note: Place the thickest cable closest to the battery terminal.

Note: If the battery is put into service after the date shown on top/side of battery, charge the battery prior to operating the machine.

Notes

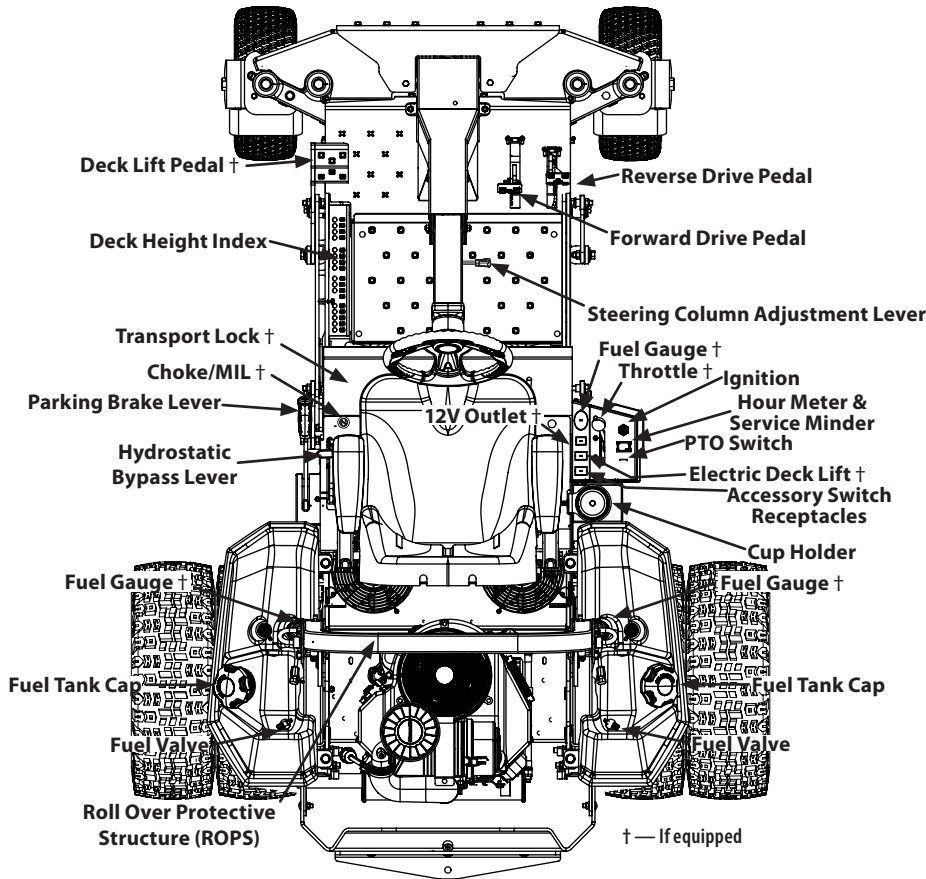

Figure 3-1

Note: All references in this manual to the left or right side and front or back of the machine are from the operating position only. Exceptions, if any, will be specified.

Note: This Operator's Manual covers several models. Tractor features may vary by model. Not all features in this manual are applicable to all tractor models and the tractor depicted may differ from yours.

Ignition Switch

The ignition switch is located on the RH console to the rear of the throttle control. The ignition switch has three positions as follows:



OFF — The engine and electrical system are turned off.

ON — The tractor electrical system is energized.

START — The starter motor will turn over the engine. Release the key immediately when the engine starts.

Note: To prevent accidental starting and/or battery discharge, remove the key from the ignition switch when the tractor is not in use.

Transmission Bypass Lever

⚠ WARNING

Do not tow the tractor, even with the bypass valves engaged. Serious transmission damage will result from doing so.

The transmission bypass lever is located next to the LH console to the left of the operator's seat.

When engaged the valves open a bypass within the hydrostatic transmissions. Refer to the Assembly & Set-Up section for instructions on using the bypass feature.

Power Take-Off (PTO) Knob

The PTO knob is located on the RH console to the right of the operator's seat.

The PTO knob operates the electric PTO clutch mounted on the bottom of the engine crankshaft. Pull the knob upward to engage the PTO clutch, or push the knob downward to disengage the clutch.

The PTO knob must be in the "OFF" position when starting the engine.

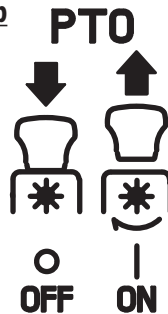

Hour Meter & Service Minder

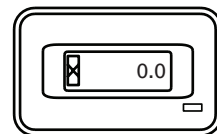

The hour meter and service minder is located on the RH console to the right of the operator's seat. It records the hours that the tractor has been operated, engine speed (RPM), and service reminders (oil, lube) in the digital display.

The hour meter and service minder is activated whenever the ignition switch is turned to the "ON" position. Keep a record of the actual hours of operation to assure all maintenance procedures are completed according to the instructions in this Operator's Manual and the Engine Operator's Manual. The hour meter and service minder is equipped with a MODE button that can toggle between available functions and can be used to reset service alerts. Press and hold the MODE button for three (3) seconds while in service alert mode or when in a service alarm mode to reset.

Note: When the ignition key is out of the STOP position the hourglass symbol is illuminated/blinks to indicate it is recording the hours of tractor operation, regardless of whether the engine is started.

Throttle

Manual Throttle (If equipped)

The throttle control is located on the RH console to the right of the operator's seat. When set in a given position, a uniform engine speed will be maintained. The throttle control moves between the FAST and SLOW positions.

Push the throttle control handle forward to increase the engine speed. The tractor is designed to operate with the throttle control in the FAST (full throttle) position when the tractor is being driven and the mower deck is engaged.

Pull the throttle control handle rearward to decrease the engine speed.

Electronic Throttle (E-Governor) Lever (If equipped)

The electronic throttle (E-governor) lever is used to control engine speed and RPM's. It also helps control fuel efficiency. The electronic throttle lever moves between the FAST and SLOW position is used for basic transportation of the tractor with the PTO disengaged and uses the least fuel. The FAST position should be used when the PTO is engaged and uses the most fuel. The tractor should be started in the START position, but should always be in the FAST position when the PTO/deck is being used.

Choke Knob (If equipped)/

MIL (If equipped)

Choke Knob (If equipped) - The choke knob is located on the left side of the mower next to the operator's seat. Pull the knob out to choke the engine; push the knob in/down to open the choke. Having the choke in the ON position helps the engine to start during initial start-up. During normal operation the choke should be OFF.



MIL (If equipped) - The Multifunction Indicator Light (MIL) provides diagnostic information for the engine. If the MIL lights up and/or flashes see the service manual or contact your service center.

Parking Brake Lever

The parking brake lever is located to the left of the operator's seat. When pulled up it engages the parking brake and when pushed down it releases the brake.

Note: If the forward or reverse drive pedal is engaged when engaging the parking brake, the engine will stop. The parking brake must be placed in the engaged position when starting the engine.



Forward Drive Pedal

The forward drive pedal is located on the right side of the machine, directly to the right of the steering column and along the running board. Press the forward drive pedal forward to cause the tractor to travel forward. Ground speed is also controlled with the forward drive pedal. The further forward the pedal is pivoted, the faster the tractor will travel. The pedal will return to its original/neutral position when it is not pressed.

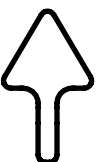

Reverse Drive Pedal

The reverse drive pedal is located on the right side of the tractor, to the right of the forward drive pedal, along the running board. Ground speed is also controlled with the reverse drive pedal. The further downward the pedal is pivoted, the faster the tractor will travel. The pedal will return to its original/neutral position when it is not pressed.



Fuel Tank Caps

The fuel tank caps are located on the top of the fuel tank on the left and right side of the seat. Turn the fill cap counter-clockwise to remove and clockwise until it clicks three times to tighten. Always re-install the fuel cap tightly onto the fuel tank after removing.

⚠ WARNING

Never fill the fuel tank when the engine is running. If the engine is hot from recently running, allow to cool for several minutes before refueling. Highly flammable gasoline could splash onto the engine and cause a fire.

Seat Adjustment Lever (Not shown)

The seat adjustment lever is located below the front/right of the seat. The lever allows for adjustment forward or rearward of the operator's seat. Refer to the Assembly & Set-Up section for instructions on adjusting the seat position.

Seat Tilt Knob (Not shown)

The seat tilt knob is located on the left side of the seat. Refer to the Assembly & Set-Up section for instructions on adjusting the seat tilt.

Arm Rest Height Knobs (Not shown, if equipped)

The arm height knobs are located under the seat arms and can be used to adjust the height of the arm rests. Refer to the Assembly & Set-Up section for instructions on adjusting the arm rest position.

Mechanical Suspension Mechanism (Not shown, if equipped)

The mechanical suspension mechanism is located on the front of the seat and can adjust the weight/ride adjustment for operators in the 125- to 275-pound weight range. Refer to the Assembly & Set-Up section for instructions on adjusting the mechanical suspension mechanism.

Lumbar Support Lever (Not shown, if equipped)

The lumbar support lever is located on the right side of the seat on the seat back. Refer to the Assembly & Set-Up section for instructions on adjusting the lumbar support.

Seat Prop (Not shown)

The seat prop is located on the left, rear side of the operator's seat. It is used to prop the seat forward.

Seat Latch (Not shown)

The seat latch is located below the rear, center of the operator's seat. The latch is used to secure the seat into the operating position. Lift the latch and tilt the seat forward to access the area under the seat.

Deck Height Index



The deck height index consists of several holes located on the left of the foot platform. Each hole corresponds to a 1/4" change in the deck height position ranging from 1" at the lowest notch to 5" at the highest notch.

Deck Lift

Deck Lift Pedal (If equipped)

The deck lift pedal is located on the left front corner of the foot platform, and is used to raise and lower the mowing deck.

To raise the mowing deck to the transport position, push the pedal all the way forward until the deck transportation lock snaps into position. To remove the deck from the transport position push forward on the deck lift pedal and pull up on the deck lock rod. To position the deck push the pedal all the way forward, remove the clevis pin, reinsert it in the desired cutting height and slowly release pressure on the pedal until you reach the clevis pin.

Transport Lock (If equipped)

The transport lock is located on the left side of the operator's seat and is used to lock the deck in the transport position. Press down on the deck lift pedal and lift up on the deck lift release lever to release the deck.

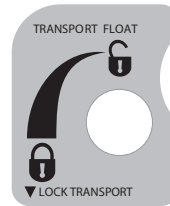

Transmission Oil Expansion Reservoir (Not shown, if equipped)

The 500 series is equipped with an integrated transmission oil expansion reservoir on both the LH and RH transmission assemblies. The 700 and 900 series are equipped with a transmission oil expansion reservoir located under the seat, connected by hoses to the RH and LH transmission assemblies. The function of the reservoir is to hold the natural expansion of transmission oil that occurs as the transmission warms up during operation. DO NOT FILL THE RESERVOIR.

Under normal operating conditions, no oil should be added to the reservoir. The COLD oil level should be approximately 1/4" above the bottom of the reservoir on 700 and 900 models and 1/8" up the dipstick on 500 models. See the Product Care section of this manual for more information on the transmission oil expansion reservoirs.

Note: Prior to the initial operation of the tractor, the oil level in the reservoir may be slightly higher than the maximum due to air in the oil lines. Operation of the tractor will eventually purge the air from the lines and the oil level will settle to the maximum.

Steering Column Adjustment Lever

The steering column adjustment lever is located on the right side of the steering column. To adjust the column pull up on the steering column adjustment lever and move the steering column up into the desired position. Release the steering column adjustment lever to secure the steering column in the desired position.

Cup Holder

The cup holder is located between the fuel tank and the control panel to the right of the seat.

Roll Over Protective Structure (ROPS)

ROPS Positions

Refer to Figure 3-2 and the following descriptions and uses for the three (3) positions for the ROPS.

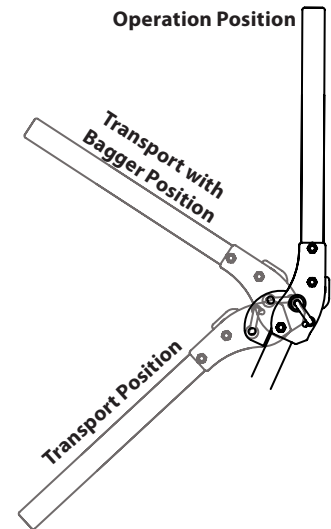

Figure 3-2

- **TRANSPORT:** Only to be used when transporting the tractor or when they need to be momentarily folded-down to avoid contact with items such as tree limbs, clothes lines, guy wires, utility poles, buildings, etc.
 - **TRANSPORT WITH BAGGER:** Allows for the ROPS to be lowered for situations outlined for the TRANSPORT position when the tractor is equipped with a bagger.
 - **OPERATION:** The ROPS should always be in this position when operating unless the situations involved outlined in the TRANSPORT and TRANSPORT WITH BAGGER descriptions arise.
1. To change the position of the ROPS, pull slightly up/push forward on the upper ROPS to relieve any tension on the locking pin (a) and rotate the locking pin (a) from the LOCKED (b) position into the ADJUSTMENT (c) position. Repeat the procedure for the locking pin on the opposite side. See Figure 3-3.

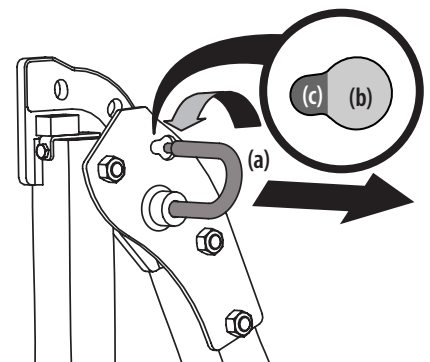

Figure 3-3

2. Move the ROPS into the desired position. The three positions are TRANSPORT position, TRANSPORT WITH BAGGER position and into the OPERATION position. See Figure 3-2.

3. Rotate both locking pins into the LOCKED position. Move the upper ROPS slightly until the locking pins are fully engaged in the LOCKED position.

Accessory Switch Receptacles

The two receptacles for optional accessories are on the RH console. See the Attachments & Accessories section for information.

12V Outlet (If equipped)

The 12V outlet is located to the right of the operator's seat on the lower panel of the RH console and is used for the convenience of plugging in accessories that require a power source with a maximum load of 5A at 12V.

Fuel Gauge(s)

There is a fuel gauge on top of each of the two fuel tanks or a single gauge to the right of the operator's seat on the RH console. The gauges measure the fuel level in each tank.



Fuel Valves

The fuel valves are located near the rear of each fuel tank. The valve controls the fuel flow from the right and left tank and also can shut off fuel flow to the engine. Rotate the valve counter-clockwise to open the flow from the tank(s). Rotate the valve clockwise to stop the flow from the tank(s). The fuel tanks can be operated together, independently or shut the fuel flow off completely.



Note: If both tanks are on, and one is empty, the engine will not start. Be certain to make sure both tanks have fuel or that the empty tank's fuel valve is closed.

Before Operating Your Tractor

1. Before you operate the tractor, study this manual carefully to familiarize yourself with the operation of all the instruments and controls. It has been prepared to help you operate and maintain your machine efficiently.
2. Fill the fuel tank with only clean, fresh, unleaded gasoline with a pump sticker octane rating of 87 or higher. When the fuel reaches 1/2" below the bottom of the fill neck, stop. DO NOT OVERFILL. Space must be left for expansion.
3. Never use gasoline containing more than 10% ethanol or methanol.
4. Check the engine oil level as instructed in the Engine Operator's Manual.
5. Check the transmission oil level. The transmission oil expansion reservoir is located beneath the operator's seat. Always wipe off the area around the reservoir fill neck before checking the oil level to prevent dirt from contaminating the oil. Remove the cap and make sure the oil level is 1/4" above the bottom of the reservoir. If the oil level is low, fill with Castrol™ (Syntec®) Edge™.

6. Check the tire inflation pressures. 10-12 psi for the rear tires, 20-25 psi for the front tires.

Note: New tires are over-inflated in order to properly seat the bead to the rim.
7. Check that all nuts, bolts and screws are tight.
8. Check the tension of the deck drive belts.
 - a. Remove the deck cover.
 - b. The tension of the deck drive belts are maintained by a spring mechanism that adjusts for wear and stretch.
 - c. Examine the belts for cuts, fraying and excessive wear. Replace if any of these are detected.
 - d. Replace the deck cover.
9. Check if deck is level. When correctly adjusted the mower deck should be level side to side, and the front of the deck should be approximately 1/4" lower than the rear of deck. If deck needs to be leveled, refer to the Product Care section.
10. Lubricate all pivot points listed in the Product Care section.
11. Adjust the seat for operator's maximum comfort, visibility and for maintaining complete control of the machine. Refer to the Assembly & Set-Up section for instructions on adjusting the seat.

Safety Interlock System

This machine is equipped with a safety interlock system for the protection of the operator. If the interlock system should ever malfunction, do not operate the machine. Contact your authorized service dealer.

- The safety interlock system prevents the engine from cranking or starting unless the speed control pedals are in the neutral position, the parking brake is engaged and the PTO knob is disengaged.
- To avoid sudden movement when disengaging the parking brake, the safety interlock system will shut off the engine if the speed control pedals are moved to a position other than the neutral position when the parking brake is engaged.
- The safety interlock system will shut off the engine if the operator leaves the seat before engaging the parking brake.
- The safety interlock system will shut off the engine if the operator leaves the seat with the PTO knob engaged, regardless of whether the parking brake is engaged.

Note: The PTO knob must be in the disengaged position to restart the engine.

Starting the Engine

For throttle/choke or throttle/automatic EFI engines proceed below, for electronic throttle/EFI engines, skip ahead to the Electronic Throttle/EFI (Electronic Fuel Injection) Engines section.

Manual Throttle/Choke or Throttle/Automatic EFI (Electronic Fuel Injection) Engines

▲ WARNING

This machine is equipped with a safety interlock system designed for protection of the operator. Do not operate the machine if any part of the interlock system is malfunctioning. Periodically check the functions of the interlock system for proper operation.

▲ WARNING

For personal safety, the operator must be sitting in the tractor seat when starting the engine.

1. Open the fuel valve(s).

Note: If both tanks are on, and one is empty, the engine will not start. Be certain to make sure both tanks have fuel or that the empty tank's fuel valve is closed.
2. Operator must be sitting in the tractor seat with both drive control pedals in the neutral/start position.
3. Engage the parking brake.
4. Make certain the PTO is in the disengaged (down) position.
5. Lift the choke knob (if equipped) into the ON position.

Note: If the engine is warmed up, it may not be necessary to choke the engine.

Note: Some tractors are equipped with EFI (Electronic Fuel Injection) engines and are not equipped with a choke.
6. Move the throttle control to midway between the SLOW and FAST positions.
7. Turn the ignition key clockwise to the START position and release it as soon as the engine starts; however, do not crank the engine continuously for more than 10 seconds at a time. If the engine does not start within this time, turn the key to OFF and wait at least 30 seconds to allow the engine's starter motor to cool. Try again after waiting. If after a few attempts the engine fails to start, do not keep trying to start it with the choke closed as this will cause flooding and make starting more difficult.
8. Once the engine starts, push the choke (if equipped) halfway down and as the engine warms, push the choke (if equipped) all the way down.

Electronic Throttle(E-Governor)/EFI (Electronic Fuel Injection) Engines

1. Open the fuel valve(s).

Note: To prime a dry fuel system, turn the ignition switch to the ON position for one minute. Allow the fuel pump to cycle and prime the system. Turn the ignition switch to the OFF position.

Note: If both tanks are on, and one is empty, the engine will not start. Be certain to make sure both tanks have fuel or that the empty tank's fuel valve is closed.
2. Operator must be sitting in the tractor seat with both drive control pedals in the neutral/start position.
3. Engage the parking brake.
4. Make certain the PTO is in the disengaged (down) position.
5. Place the Electronic Throttle lever in the START position.
6. Turn the ignition key clockwise to the START position and release it as soon as the engine starts; however, do not crank the engine continuously for more than 10 seconds at a time. If the engine does not start within this time, turn the key to OFF and wait at least 60 seconds to allow the engine's starter motor to cool. Try again after waiting.

Note: Failure to follow these guidelines can burn out the starter motor.

Note: Upon start-up, a metallic ticking may occur. Run engine for 5 minutes. If the noise continues, run the engine at the starting position for 20 minutes. If the noise persists, take the tractor to your authorized service dealer.

Cold Weather Starting

When starting the engine at temperatures near or below freezing, ensure the correct viscosity motor oil is used in the engine and the battery is fully charged. Start the engine as follows:

1. Be sure the battery is in good condition. A warm battery has much more starting capacity than a cold battery.
2. Use fresh winter grade fuel. Winter grade gasoline has higher volatility to improve starting. Do not use gasoline left over from summer.
3. Follow the previous instruction for Starting the Engine.

Using Jumper Cables to Start Engine

⚠ WARNING

Batteries contain sulfuric acid and produce explosive gases. Make certain the area is well ventilated, wear gloves and eye protection, and avoid sparks or flames near the battery.

If the battery charge is not sufficient to crank the engine, recharge the battery. If a battery charger is unavailable and the tractor must be started, the aid of a booster battery will be necessary. Connect the booster battery as follows:

1. Connect the end of one cable to the disabled tractor battery's positive terminal; then connect the other end of that cable to the booster battery's positive terminal.
2. Connect one end of the other cable to the booster battery's negative terminal; then connect the other end of that cable to the frame of the disabled tractor, as far from the battery as possible.
3. Start the disabled tractor following the normal starting instructions previously provided; then disconnect the jumper cables in the exact reverse order of their connection.
4. Have the tractor's electrical system checked and repaired as soon as possible to eliminate the need for jump starting.

Stopping the Engine

1. Place the PTO switch in the disengaged position.
2. Engage the parking brake.
3. Move the throttle to the SLOW  position and allow the engine to idle for about one minute.
4. Turn the ignition key to the OFF position and remove the key from the ignition switch.

Note: Always remove the key from the ignition switch to prevent accidental starting or battery discharge if the equipment is left unattended.

5. Close the fuel shut-off valve(s).

Practice Operation (Initial use)

Operating a zero-turn tractor is not like operating a conventional type riding tractor. Although and because a zero-turn tractor is more maneuverable, getting used to operating the speed control pedals and the steering wheel takes some practice.

It is strongly recommended that you locate a reasonably large, level and open "practice area" where there are no obstructions, pedestrians or animals. You should practice operating the tractor for a minimum of 30 minutes.

Carefully move (or have moved) the tractor to the practice area. When performing the practice session, the PTO knob should not be engaged. While practicing, operate the tractor at approximately 1/2-3/4 throttle and at less than full speed in both forward and reverse.

Always wear appropriate clothing and personal protection equipment (e.g. safety glasses, long pants, gloves, hearing protection, safety shoes, hard hat) when operating or maintaining this machine. Follow all federal, state and local guidelines regarding the use of personal protective equipment.

⚠ WARNING

Hearing protection is required for all operator exposure exceeding two (2) hours.

Carefully practice maneuvering the machine using the instructions in the Driving the Tractor section. Practice until you are confident that you can safely operate the tractor.

Driving the Tractor

1. Ensure that the area is free of animals and bystanders, especially children.
2. Survey the area where the equipment is to be used to make sure it is free of debris, sticks, stones, wires, bones and other foreign objects which could cause injury to bystanders, damage to the machine or damage to nearby facilities.

⚠ WARNING

Avoid sudden starts, excessive speed, and sudden stops.

3. Adjust the operator's seat to the most comfortable position that allows you to operate the controls. Refer to the Assembly & Set-Up section for instructions on adjusting the seat.
4. Adjust the steering wheel tilt with the steering column adjustment lever.
5. Release the parking brake.
6. Move the throttle control lever (if equipped) forward to the FAST  position.

Note: The tractor's engine is designed to run at full throttle, but when performing a practice session the tractor must be operated at less than full throttle. This only applies to practice.

⚠ WARNING

Always maintain a firm grip on the steering wheel.

7. To drive the tractor, firmly grasp the steering wheel with your right and left hands and continue with Driving the Tractor Forward.

Driving the Tractor Forward

⚠ WARNING

Keep all movement of the drive pedals slow and smooth. Abrupt movement of the pedals can affect the stability of the tractor and could cause the tractor to flip over, which may result in serious injury or death to the operator.

1. Slowly push the forward drive pedal forward. The tractor will start to move forward. See Figure 3-4.

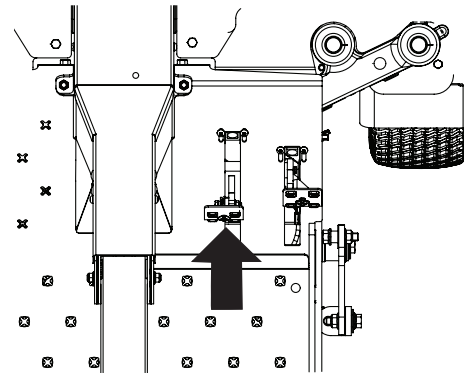

Figure 3-4

2. As the forward drive pedal is pushed farther forward the speed of the tractor will increase.
3. To slow the tractor, slowly release the forward drive pedal to attain the desired speed, or allow to pedal to return to the neutral position to stop the tractor.

Turning the Tractor While Driving Forward

⚠ WARNING

When reversing the direction of travel, performing gradual "U" turns where possible is recommended. Sharper turns increase the possibility of turf defacement, and could affect control of the tractor. ALWAYS slow the tractor before making sharp turns.

To turn the tractor while driving forward, use the steering wheel to turn in the direction you wish to travel.

1. To turn to the left, turn the steering wheel counter-clockwise (to the operator's left).
2. To turn to the right, turn the steering wheel clockwise (to the operator's right).
3. The greater the distance the steering wheel is turned, the sharper the tractor will turn.
4. To execute a "pivot turn," move the steering wheel so that the inside wheel is angled at approximately 88° and the turn side tire will not rotate.

Note: Making a "pivot turn" on grass will greatly increase the potential for defacement of the turf as well as potential damages to the traction surface and the tire.

Driving the Tractor in Reverse

⚠ WARNING

Always look behind and down on both sides of the tractor before backing up. Always look behind while traveling in the reverse direction.

1. Slowly push the reverse drive pedal forward. The tractor will start to move in the reverse direction. See Figure 3-5.

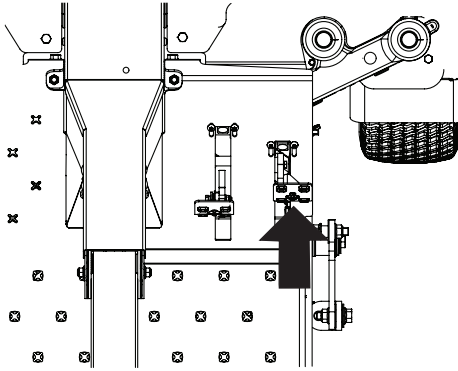

Figure 3-5

2. As the reverse drive pedal is pushed farther forward the speed of the tractor will increase.
3. To slow the tractor release the reverse drive pedal to attain the desired speed, or allow the pedal to return to the neutral position to stop the tractor.

Turning While Driving Rearward

To turn the tractor while driving rearward, use the steering wheel to turn in the direction you wish to travel.

1. To turn to the left while traveling in reverse, turn the steering wheel clockwise (to the operator's right).
2. To turn to the right while traveling in reverse, turn the steering wheel counter-clockwise.
3. The greater the distance the steering wheel is turned, the sharper the tractor will turn.
4. To execute a "pivot turn," move the steering wheel so that the inside wheel is angled at approximately 88° and the turn side tire will not rotate.

Note: Making a "pivot turn" on grass will greatly increase the potential for defacement of the turf as well as potential damages to the traction surface and the tire.

Executing a Zero Turn

1. A zero turn maneuver can be executed while the machine is moving in the forward or reverse directions if the steering wheel is turned completely in the one direction.
2. To turn clockwise when going forward, turn the steering wheel clockwise and depress the forward drive pedal. Release the pedal and the machine should stop turning. If the reverse drive pedal is depressed, the turn will be counter-clockwise.
3. To turn counter-clockwise when going forward turn the steering wheel counter-clockwise and depress the forward drive pedal. Release the pedal and the machine should stop turning. If the reverse drive pedal is depressed, the turn will be clockwise.

Stopping the Tractor

1. Allow the forward and reverse drive pedals to return to the neutral position to stop the motion of the tractor.
2. Push the PTO knob downward to the disengaged position.
3. Use the deck lift pedal to raise the deck to its highest position.
4. If dismounting the machine, allow the drive pedals to return to the neutral position, engage the parking brake, turn the ignition switch to OFF and remove the key from the switch.

⚠ WARNING

Do not leave the seat of the tractor without disengaging the PTO, moving drive pedals to the neutral position engaging the parking brake. If leaving the tractor unattended, turn the ignition key OFF and remove.

Driving on Slopes

Refer to the slope gauge in the Safe Operation Practices section to help determine slopes where you may not operate safely.

⚠ WARNING

Do not operate on inclines with a slope in excess of 20°/35% (a rise of approximately 4 feet every 10 feet). The machine could overturn and cause serious injury.

1. Always drive across slopes, never up and down.
2. Avoid turning downhill if possible. Start at the bottom of a slope and work upward. Always slow down before turning.
3. Use extra care and go slowly when turning downhill.

Operating the PTO knob

Operate the PTO knob as follows:

1. Move the throttle control lever (if equipped) to approximately the mid-throttle position.
2. Pull the PTO knob switch upward to the "ENGAGED" position.
3. Advance the throttle control lever to the operating speed (full engine speed).
4. The operator must remain in the tractor seat at all times. If the operator should leave the seat without turning off the power take-off switch, the tractor's engine will shut off.

Using the Mower Deck

⚠ WARNING

Make certain the area to be mowed is free of debris, sticks, stones, wire, or other objects that can be thrown by the rotating blades.

Note: Do not engage the mower deck when lowered in grass. Premature wear and possible failure of the "V" belt and PTO clutch will result. Fully raise the deck or move to a non-grassy area before engaging the mower deck.

1. Use the deck lift pedal (a) or push down on the back of the electric deck lift switch (b) to raise the deck to its highest position, place the clevis pin (c) attached to the tractor into the desired index hole on the deck height index, then slowly release the deck lift pedal (a) or slowly lower the deck by pressing down on the front of the electric deck lift switch (b). See Figure 3-6.

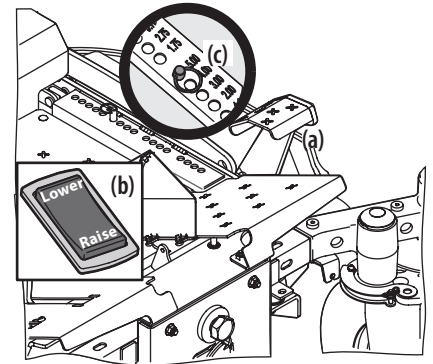

Figure 3-6

2. Mow across slopes, not up and down. If mowing a slope, start at bottom and work upward to ensure turns are made uphill.
3. On the first pass pick a point on the opposite side of the area to be mowed.
4. Engage the PTO knob and move the throttle control to the FAST position.
5. Remove the clevis pin, raise the deck to the highest (transport) position, place the clevis pin in the desired position and secure with the clevis pin. Lower the mower deck to the desired height setting.
6. Slowly push the forward drive pedal forward to move the tractor forward, and keep the tractor headed directly toward the alignment point.
Note: The speed of the tractor will affect the quality of the mower cut. Mowing at full speed will adversely affect the cut quality. Control the ground speed with the drive pedals.
7. When approaching the other end of the strip, slow down or stop before turning. A U-turn is recommended unless a pivot or zero turn is required.
8. Align the mower with an edge of the mowed strip and overlap approximately 3".
9. Direct the tractor on each subsequent strip to align with a previously cut strip.
10. To prevent rutting or grooving of the turf, if possible, change the direction that the strips are mowed by approximately 45° for the next and each subsequent mowing.

⚠ WARNING

Be careful when crossing gravel paths or driveways. Disengage the PTO knob and raise the deck to the highest/transport position before crossing.

Note: When stopping the tractor for any reason while on a grass surface, always:

- Make sure the drive pedals are in neutral.
- Engage the parking brake.
- Shut engine off and remove the key.
- Doing so will minimize the possibility of having your lawn "browned" by hot exhaust from your tractor's running engine.

Mower Cutting Blades

The blades normally factory installed on a mower afford the best grass cutting performance on the majority of grasses and mowing conditions; however, there will be occasions whereby the grass type, stage of grass growth, soil conditions and weather conditions will require different cutting blade types. Since the mower decks are designed so that over-lap of the cutting blades generally exceed 1.5", there is no need for orientation of one cutting blade to an adjacent blade (i.e., the blades do not need to be "timed" nor synchronized).

Hi-lift — These are generally the best cutting blades for most grasses and mowing conditions. The hi-lift blades are the factory installed blades on these tractors. These blades will provide extra "lift" for the thinner leaf grasses, will handle lush grasses and will provide maximum grass and debris discharge. These blades are generally required for material collection systems. More horsepower is required for these blades when compared to others, and they generally produce the highest noise levels.

Medium-lift — These blades require less horsepower than the hi-lift, and they generally work well in wider leaf grasses and some mulch applications.

Low-lift — These blades require less horsepower than hi-lift and medium-lift blades, and they generally work best with wide leaf grasses, sparse grass growth and sandy soil conditions. They produce the lowest noise levels. Low-lift blades are configured without offset, and with a maximum amount of sharpened cutting edge.

Mulch — These blades are generally designed for use in cutting decks equipped with mulch baffles. The shape of the blade generally produces higher turbulence in order that the grass can be repeatedly cut and re-cut into smaller pieces. These blades generally require more horsepower than other blades. Mulch blades work best when the grasses are cut at the highest levels, minimal lengths of grasses are removed and grass conditions are generally dry.

Note: Refer to the Attachment & Accessories section for a list of part numbers.

Reconfigurable Mower

	Inner Baffle	Discharge Baffle	Cutting Blades	Gauge Wheels	Front Roller	Rear Rollers
Standard set-up	Installed	Installed	Hi-lift	Low = 3 to 5"	Low = 3 to 5"	Low = 3 to 5"
Stems (Dandelion, Bahia, Buckhorn, etc.)	Removed	Installed	Hi-lift	High = 1 to 2-1/2" Low = 3 to 5"	High = 1 to 2-1/2" Low = 3 to 5"	High = 1 to 2-1/2" Low = 3 to 5"
Very lush &/or tall grass	Removed	Installed	Hi-lift	High = 1 to 2-1/2" Low = 3 to 5"	High = 1 to 2-1/2" Low = 3 to 5"	High = 1 to 2-1/2" Low = 3 to 5"
Low cut height (1 to 2")	Installed	Installed	Low-lift	High = 1 to 2-1/2"	High = 1 to 2-1/2"	High = 1 to 2-1/2"
Mulch	Installed	Removed	Hi-lift/Mulch	High = 1 to 2-1/2" Low = 3 to 5"	High = 1 to 2-1/2" Low = 3 to 5"	High = 1 to 2-1/2" Low = 3 to 5"
Material collection	Installed	Installed	Hi-lift	High = 1 to 2-1/2" Low = 3 to 5"	High = 1 to 2-1/2" Low = 3 to 5"	High = 1 to 2-1/2" Low = 3 to 5"
Abrasive (sandy), dry	Removed	Installed	Low-lift	High = 1 to 2-1/2" Low = 3 to 5"	High = 1 to 2-1/2" Low = 3 to 5"	High = 1 to 2-1/2" Low = 3 to 5"
Wet	Installed	Installed	Hi-lift	High = 1 to 2-1/2" Low = 3 to 5"	High = 1 to 2-1/2" Low = 3 to 5"	High = 1 to 2-1/2" Low = 3 to 5"

Table Notes: This table is a general outline of suggested settings, mowing conditions may vary.

Inner Baffle: The inner baffle regulates grass discharge. Remove the inner baffle for high-volume grass and install the inner baffle for precision cutting.

Discharge Baffle: The discharge baffle enhances the grass discharge pattern. The discharge baffle reduces clumping and should be removed for mulching.

Cutting Blades: The cutting blades cut grass, create grass lift and discharge grass through the discharge chute.

Gauge Wheels: The gauge wheels reduce scalping, help with precision cutting and reduce turf defacement during turns.

Front Roller: The front roller reduces scalping, helps with precision cutting and reduces turf defacement during turns.

Rear Rollers: The rear rollers reduce scalping and gives grass a striped appearance.

NOTE: To avoid damaging grass, no more than 1/3 of the grass height should be removed during a single cutting (i.e. if the grass is 6" tall, cut it to 4").

Product Care

Maintenance Schedule

	Before Each Use	Every 25 Hours	Every 50 Hours	Every 500 Hours	After Mowing
Check Gasoline Level	✓				
Check Hydraulic Hoses for Leaks	✓				
Check Tires & Tire Pressure	✓				
Check Deck, Mower & Hydro Drive Belts	✓				
Check Blades & Blade Bolt Tightness	✓				
Check Safety Switches for Proper Operation	✓				
Check Fluid Level in Transmission Oil Expansion Reservoir	✓				
Check/Clean Engine Intake Screens & Cooling Fans *	✓				✓
Check/Clean Exhaust Manifold, Muffler Pipe & Muffler Shields *	✓				✓
Check/Clean Top & Underside of Deck, Under & Around Spindle Covers & Belt Area *	✓				✓
Check/Clean Around Fuses, Wiring & Wiring Harnesses *	✓				✓
Check/Clean Around Transmission, Axle & Fans *	✓				✓
Blow Out/Clean Pump Control Area Under Floor Pan					✓
Blow Out/Clean Pedal Control Area Under Foot Rest					✓
Lubricate Wear Points (See chart)			✓		✓
Clean Engine Cooling Fins & External Surfaces *			✓		
Change Hydrostatic Fluid & Filter in Transaxles †				✓	

† — After first 300 hours, change hydrostatic fluid and filter in transaxles.

* — Perform more frequently under dusty conditions.

OIL CHART

Apply a few drops of SAE engine oil, grease or use a spray lubricant. Apply the oil to both sides of pivot points. Wipe off any excess. Start engine and operate mower briefly to ensure that oil spreads evenly.

Number of Oil Points	Description
DAILY	
4	Deck Suspension Pivots
4	Height Adjustment Turnbuckle Clevis Pin
2	Height Adjustment Handle Pivots
2	Height Adjustment Stop Pivots
2	Deck Lift Linkage Pivots
2	Transport Handle Pivots
1	Transport Handle Pin
2	Deck Frame Up-and-Down Pivots
WEEKLY	
1	Seat Hinge
2	Speed Control Linkage Rod End Bearings
2	Pump Control Lever Pivots
1	Brake Lever Pivot Clevis Pin
1	Brake Lever Control Rod Pivot
1	Brake Control Rod Swivel Joint
4	Brake Rod Clevis Pins
2	Brake Shaft Assembly Pivots
2	Grass Collection System Lid Hinges (If mower is so equipped)

Engine Oil

- Shell Rotella® T Triple Protection™ 15W40
- Shell Rimula® 15W40
- Reference your Engine Operator's Manual for other approved options

Hydrostatic Fluid

- Drive System Fluid Plus (Shell TT-5B)
- Castrol™ (Syntec®) Edge™ 5W50

General Purpose Lubrication: Use any NLGI Grade 2 multi-purpose grease. Shell Albida EP2 is recommended. Shell Albida EP 2 is a red-colored multi-purpose grease designed for heavy-duty bearing applications. It has high base oil viscosity for mechanical stability, has been formulated for high load, low-speed applications and has excellent lubrication and corrosion protection.

Note: This Operator's Manual covers several models. Tractor features may vary by model. Not all features in this manual are applicable to all tractor models and the tractor depicted may differ from yours.

Maintenance

⚠ WARNING

Before performing any maintenance or repairs, disengage the PTO, move the drive pedals to the neutral position engaging the parking brake, stop the engine, and remove the key to prevent unintended starting.

Post-Operation Tractor Care

After each operation of the tractor, the following procedures should be implemented to extend the life of your tractor and ensure safe operating conditions.

⚠ DANGER

Failure to follow these recommendations may result in serious injury to yourself or others and may cause damage to the tractor.

Cleaning the Underside of the Deck

Rinse grass clippings from the deck's underside and prevent the buildup of corrosive chemicals.

⚠ WARNING

Make certain the tractor's discharge chute is directed AWAY from people, your house, garage, parked cars, etc.

1. Disengage the PTO, set the parking brake and stop the engine.
2. Use a hose to spray the underside of the deck.

Note: Make sure that the hose is not routed under the deck and is clear of all moving parts.
3. After cleaning your deck, return to the operator's position and engage the PTO. Keep the deck running for a minimum of two minutes, allowing the underside of the deck to thoroughly dry.

Cleaning the Tractor

⚠ WARNING

If the tractor has been recently run, the engine, muffler, and surrounding metal surfaces will be hot and can cause burns to the skin. Let the engine cool for at least 5 minutes. Exercise caution to avoid burns.

Your tractor should be cleaned after each use and under certain conditions, i.e. dry conditions and/or mulching situations, additional cleaning may be necessary.

One of the best ways to keep your tractor running efficiently and to reduce fire risk is to regularly remove debris buildup from the tractor. Follow the recommendations below and contact your authorized dealer with any questions.

- Allow the machine to cool in an open area before cleaning.
- Do not use water on any part of the tractor except the underside of the cutting deck. Doing so can cause damage to the tractor's spindle bearings, electrical system and engine, leading to premature failures. The use of compressed air and/or leaf blower will help keep the tractor clean.
- Clean around the exhaust manifold, fuses, all wiring and harnesses, muffler pipe, muffler shield, engine intake screens and cooling fins, etc. See Figure 4-1.

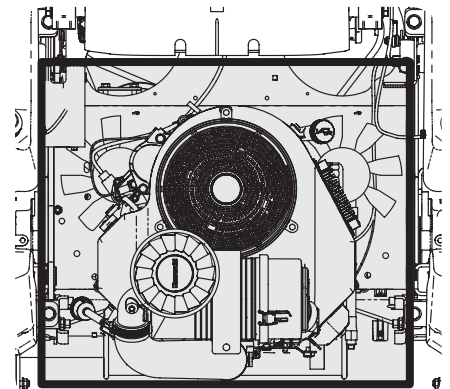

Figure 4-1

- Clean the top of the mower deck, under the spindle covers and belt area. See Figure 4-2.

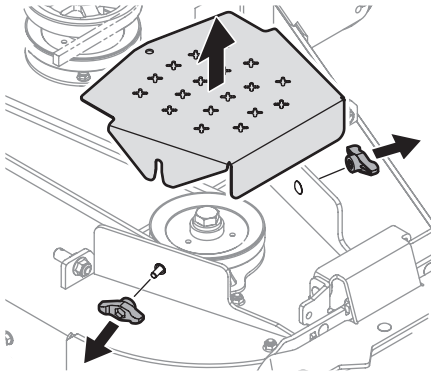

Figure 4-2

- Clean around and near the transmission, axle and the fan area. See Figure 4-3.

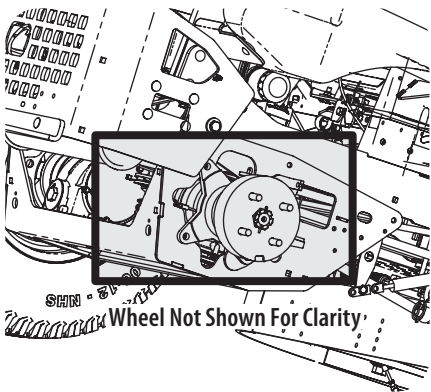

Figure 4-3

- Debris can accumulate anywhere on the tractor, especially on horizontal surfaces. Additional cleaning may be necessary when mowing in dry conditions or when mulching.
- Fuel leaks/spills, oil leaks/spills and excess lubrication can also become collection sites for debris. Immediate repair and cleaning up oil or fuel spills can help reduce fire hazards.
- In addition to cleaning the tractor before operating and storing, do not attempt to mow unusually tall grass (10" or higher), dry grass (e.g., pasture) or piles of dry leaves. Dry grass or leaves may contact the engine exhaust and/or build up on the mower deck presenting a potential fire hazard.

Storing the Tractor

- Allow the machine to cool in an open area before storing.
- Do not park the tractor near any flammable materials (wood, cloth or chemicals) or any open flames or other potential source of ignition (furnace, water heater or any other type of heater).
- Remove all combustible materials from the tractor before storing. Empty cargo boxes, grass catchers or containers.
- Always shut off fuel flow when storing or transporting if tractor is equipped with a fuel shutoff.
- Check the fuel system (lines, tank, cap and fittings) frequently for cracks or leaks. Repair and clean as necessary.

Engine

Refer to the Engine Operator's Manual for all engine maintenance intervals, procedures, specifications and instructions.

Changing the Engine Oil

⚠ WARNING

If the engine has been recently run, the engine, muffler, and surrounding metal surfaces will be hot and can cause burns to the skin. Exercise caution to avoid burns.

Maintain oil level as instructed in Engine Operator's Manual. Be careful not to spill oil on any of the belts.

To complete an oil change, proceed as follows:

1. Run the engine for a short time to warm the engine oil. The oil will flow more freely and carry away more impurities. Use care to avoid burns from hot oil.
2. Locate the oil drain hose on the engine. See Figure 4-4.

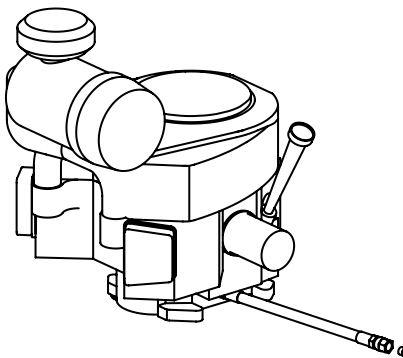

Figure 4-4

3. Remove the hose from the clip securing it to the frame.
4. Route the free end of the oil drain hose toward an appropriate oil collection container with at least a 2.5 quart capacity, to collect the used oil.

Note: Avoid getting oil on the muffler when draining.
5. While holding the free end of the oil drain hose over the oil collection container, unscrew the square-head hose plug from the end of the hose. See Figure 4-4. Drain the engine oil into the collection container.
6. Remove the oil filter to make sure all the oil is drained.
7. After draining the oil, wipe any residual oil from the oil drain hose. Thread the square head plug into the drain hose fitting and fully tighten the plug.
8. Replace the oil filter and refill the engine with new oil as instructed in the Engine Operator's Manual. Refer to the Engine Operator's Manual for information regarding the volume and weight of engine oil.
9. Place the hose back into the clip securing it to the frame.

Lubrication

Periodically lubricate all pivot points with a quality lubricating oil.

Tires

Check the tire air pressure after every 50 hours of operation or weekly. Keep the tires inflated to the recommended pressures. Improper inflation will shorten the tire service life and produce an uneven cut. See the tire side wall for proper inflation pressures. Observe the following guidelines:

- Do not inflate a tire above the maximum pressure shown on the sidewall of the tire.
- Do not reinflate a tire that has been run flat or seriously under-inflated. Have it inspected and serviced by a qualified tire mechanic.

Battery Information

⚠ WARNING

Should battery acid accidentally splatter into the eyes or onto the skin, rinse the affected area immediately with clean cold water. If there is any further discomfort, seek prompt medical attention.

If acid spills on clothing, first dilute it with clean water, then neutralize with a solution of ammonia/water or baking soda/water.

NEVER connect (or disconnect) battery charger clips to the battery while the charger is turned on, as it can cause sparks.

Keep all sources of ignition (cigarettes, matches, lighters) away from the battery. The gas generated during charging can be combustible.

As a further precaution, only charge the battery in a well ventilated area.

Always shield eyes and protect skin and clothing when working near batteries.

Batteries contain sulfuric acid and may emit explosive gases. Use extreme caution when handling batteries. Keep batteries out of the reach of children.

Battery Maintenance

- The battery is filled with battery acid and then sealed at the factory. However, even a "maintenance free" battery requires some maintenance to ensure its proper life cycle.
- Spray the terminals and exposed wire with a battery terminal sealer, or coat the terminals with a thin coat of grease or petroleum jelly, to protect against corrosion.
- Always keep the battery cables and terminals clean and free of corrosion.
- Some models are equipped with a battery containing a liquid electrolyte. Handle the battery with care and avoid tipping to prevent leakage.

⚠ WARNING

Batteries contain sulfuric acid and may emit explosive gases. Use extreme caution when handling batteries. Keep batteries out of the reach of children.

Battery Storage

1. When storing the tractor for extended periods, disconnect the negative battery cable. It is not necessary to remove the battery.
2. All batteries discharge during storage. Keep the exterior of the battery clean, especially the top. A dirty battery will discharge more rapidly.
3. The battery must be stored with a full charge. A discharged battery can freeze sooner than a charged battery. A fully charged battery will store longer in cold temperatures than hot.
4. Recharge the battery before returning to service. Although the tractor may start, the engine charging system may not fully recharge the battery.

Removing the Battery

1. Flip the seat all the way forward.
2. Unhook the strap (a) holding the battery in place. See Figure 4-5.

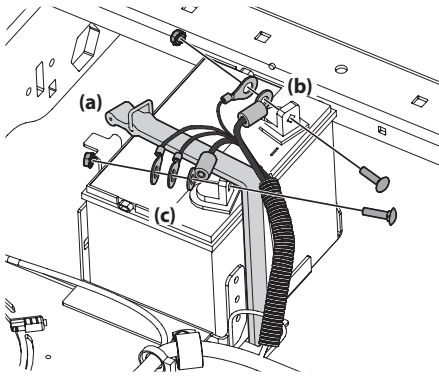

Figure 4-5

3. Remove the hex cap screw and sems nut securing the negative cable grouping (b) to the negative battery post (marked NEG). Move the cable grouping away from the negative battery post.
4. Remove the hex cap screw and sems nut securing the positive cable grouping (c) to the positive battery post (marked POS).
5. Carefully lift the battery out of the tractor.
6. Install the battery by repeating the above steps in the reverse order.

Note: Place the thickest cable closest to the battery terminal.

Using the Transmission Bypass Rods

If for any reason the tractor will not drive or you wish to move the tractor, the two hydrostatic transmissions are equipped with a bypass rod that will allow you to manually move the tractor short distances.

⚠ WARNING

Do not tow the tractor, even with the bypass rod engaged. Serious transmission damage will result from doing so.

1. Engage the transmission bypass valves by pulling the bypass lever (a) upward and all the way back. See Figure 4-6.

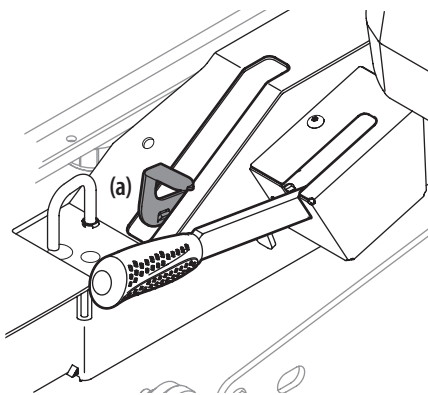

Figure 4-6

2. To release the bypass lever (a), push the lever forward.

Hydrostatic Transmission (500 Series)

The hydrostatic transmission on the 500 series is equipped with a filter and dipstick.

To check the transmission oil, locate the dipstick on both the LH and RH transmission assemblies. See Figure 4-7.

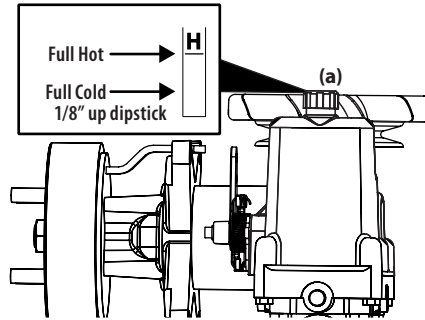

Figure 4-7

Remove the dipstick and check the oil level. When cold, the level should be no higher than 1/8" up on the dipstick. When hot the level should not exceed the "H" mark on the dipstick. Exceeding these levels could cause the oil to overflow when hot.

To change the transmission oil:

1. Remove the dipstick.
2. Place a suitable container under the drain plug (a) on the transmission. Remove the drain plug (a) and allow the transmission oil to drain. See Figure 4-8.

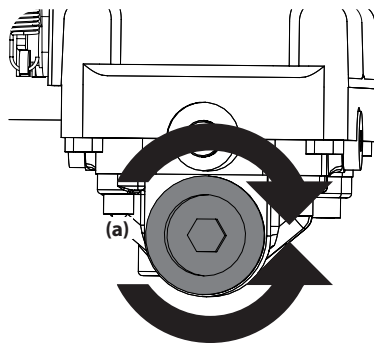

Figure 4-8

3. Using a pair of needle-nose pliers or a magnet remove the filter.
4. Replace the filter and drain plug (torque to 115-135 in-lbs) and fill the transmission assembly to 1/8" up on the dipstick.
5. Replace the dipstick.

Note: Make sure the dipstick is fully tightened. If the dipstick is not fully tightened, transmission oil could leak and cause damage to the transmission due to insufficient oil.

Hydrostatic Transmission (700 & 900 Series)

The 700 and 900 series are equipped with dual integrated hydrostatic pumps/transaxles that are equipped with a transmission oil expansion reservoir. Under normal operating conditions, the oil level in the expansion reservoir does not need to be checked and no additional oil is needed. If checking the reservoir oil level, proceed as follows:

⚠ WARNING

Check the oil level **ONLY** before starting the tractor when the transmission oil is fully cooled.

1. Pivot the operator's seat forward and clean the reservoir cap and the area around the cap to prevent debris from contaminating the transmission oil. See Figure 4-9.

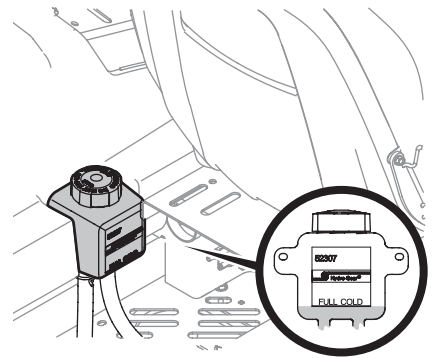

Figure 4-9

2. Turn the reservoir cap counter-clockwise to remove, then check the oil level in the reservoir. Oil should be visible at the bottom of the cup, but the oil level must NOT be above the "FULL COLD" line. See Figure 4-9. **DO NOT FILL THE RESERVOIR.**
3. If necessary to add oil because of some type of leakage, add only enough oil to bring the level to the "FULL COLD" line. Reinstall the cap and fully tighten.

Note: Prior to the initial operation of the tractor, the oil level in the reservoir may be slightly higher than the maximum due to air in the oil lines. Operation of the tractor will eventually purge the air from the lines and the oil level will settle to the maximum.

To change the transmission oil:

1. Remove the cap from the transmission oil expansion reservoir.
2. Place a suitable container under the drain plug (a) on the transmission. Remove the drain plug (a) and allow the transmission oil to drain. See Figure 4-10.

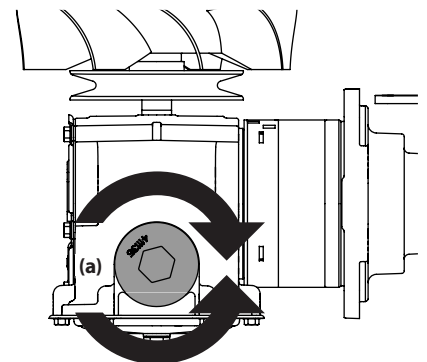

Figure 4-10

- Using a pair of needle-nose pliers or a magnet remove the filter.
- Replace the filter and drain plug (torque to 115-135 in-lbs) and fill through the expansion reservoir slowly until the "FULL COLD" line. Allow the transmission oil to move through the system and top off as necessary.
- Replace the cap and fully tighten.

Tractor Storage

If your tractor is not going to be operated for an extended period of time (30 days to approximately six months), the tractor should be prepared for storage. Store the tractor in a dry and protected location. If stored outside, cover the tractor (including the tires) to protect it from the elements. The procedures outlined below should be performed whenever the tractor is placed in storage.

- Change the engine oil and filter following the instructions provided in the Engine Operator's Manual packed with this manual.

⚠ WARNING

Never store the tractor with fuel in the tank indoors or in poorly ventilated enclosures, where fuel fumes may reach an open flame, spark, or pilot light as on a furnace, water heater, clothes dryer, etc.

- To prevent gum deposits from forming inside the engine's carburetor and causing possible malfunction of the engine, use a fuel stabilizer or completely empty the fuel system for storage between 30 and 90 days:

⚠ WARNING

Fuel left in the fuel tank deteriorates and will cause serious starting problems.

- Read the product manufacturer's instructions and recommendations.
 - Add to clean, fresh gasoline the correct amount of stabilizer for the capacity (approximately 3 gallons) of the fuel system.
 - Fill the fuel tank with treated fuel and run the engine for 2-3 minutes to get stabilized fuel into the carburetor.
- Emptying the fuel system for storage of more than 90 days:
 - Prior to putting the tractor in storage, monitor fuel consumption with the goal of running the fuel tank empty.
 - Run the engine until it begins to stall. Use the choke (if equipped) to keep the engine running until all fuel in the carburetor has been exhausted.
 - Referring to the Engine Operator's Manual, drain the fuel from the carburetor bowl.

- Clean the engine and the entire tractor thoroughly.
- Fully charge the battery, then disconnect the negative cable at the battery to prevent possible discharge. Recharge the battery periodically when in storage.

Note: Remove the battery if exposed to prolonged periods of sub-freezing temperatures. Store in a cool, dry location where temperatures are above freezing.
- Lubricate all lubrication points.

Note: Using a pressure washer or garden hose is not recommended for cleaning your tractor. It may cause damage to electrical components, spindles, pulleys, bearings or the engine. The use of water will result in shortened life and reduce serviceability.

Removing the Tractor from Storage

- Check the engine oil.
- Fully charge the battery and inflate the tires to the recommended pressure.
- Fill the fuel tank with clean, fresh gasoline.
- Start the engine and allow to idle for a few minutes to ensure engine is operating properly.
- Drive the tractor without a load to make certain all the tractor systems are functioning properly.

Adjustments

⚠ WARNING

Shut the engine off, remove the ignition key, and engage the parking brake before making adjustments. Protect your hands by using heavy gloves when handling the blades.

Deck Leveling

Note: Check the tractor's tire pressure before performing any deck leveling adjustments. Refer to Tires for information regarding tire pressure. Always level the deck side-to-side before front to rear.

Side-to-Side Leveling

- Park the mower on a flat paved surface, engage the parking brake, shut off the engine, remove the key from the ignition switch, disconnect the spark plug wires. Using the deck lift pedal position the mowing deck into the 4" height of cut position (The 4" height of cut position is recommended in order for one to see and obtain a measurement. Any height of cut position is acceptable as long as a proper measurement can be taken.) and rotate both outside blades so that they are perpendicular with the tractor.
- Measure the distance from the outside of the left blade tip to the ground and the distance from the outside of the right blade tip to the ground. Both measurements taken should be equal. If they are not, proceed to the next step.

- Adjust the eyebolt (a) at the left front of the deck so that the blade-to-ground height at the right outside blade tip matches that of the left outside blade tip. This is done by loosening the jam nuts (b) on the eyebolt (a) and tightening the upper jam nut (b) to raise the deck and loosening the jam nut (b) to lower the deck. The right outer blade tip height is fixed by the right, front eyebolt (a) so you must adjust the left outer tip to match it. See Figure 4-11.

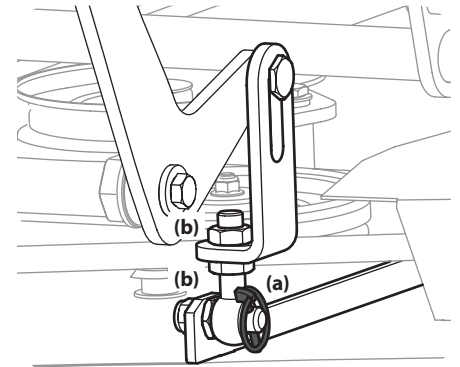

Figure 4-11

- Once the proper adjustment is made, re-tighten the jam nuts (b).

Front-to-Back Leveling

- Park the mower on a flat paved surface, engage the parking brake, shut off the engine, remove the key from the ignition switch, and disconnect the spark plug wires. Using the deck lift pedal position the mowing deck into the 4" height of cut position (The 4" height of cut position is recommended in order for one to see and obtain a measurement. Any height of cut position is acceptable as long as a proper measurement can be taken.) and rotate both outside blades so that they are parallel with the tractor.
- Measure the blade-to-ground height at the right rear blade tip. Again be sure to measure the blade tip at the rear of the right blade when aligned along the mower centerline. The blade-to-ground height at the rear of the blade tip should be 1/8" to 1/4" higher than the front tip. This is referred to as blade pitch. The same height difference should be true for the left blade, measured front and back. The pitch should not exceed 1/16" if cut height is below 1-1/2".
- Loosen the jam nuts (b) at the rear left and right of the deck eyebolts (a). Refer to Figure 4-11.
- Start at the rear right to raise the rear of the deck, tighten the upper jam nut (b) to raise the deck or loosen the upper jam nut (b) to lower the rear of the deck. Refer to Figure 4-11.
- Adjust the jam nut (b) at the rear left to take the "slack" out of the threaded rod. Refer to Figure 4-11.
- Tighten both lower jam nuts (b) to secure the deck adjustment. Refer to Figure 4-11.

- The final adjustment would be to take the "slack" out of the left rear linkage if the rear of the deck was raised by adjusting the jam nuts (b) on the eyebolt (a). Loosen the jam nuts (b) and tighten the upper jam nut (b) to remove "slack". Refer to Figure 4-11.
- In many cases it will be necessary to adjust deck height using both eyebolt (a) adjustments and pitch adjustment to achieve the correct blade-to-ground heights. If you remember that the front right blade tip adjustment is fixed and you level to that height, adjusting the decks will be simplified. Refer to Figure 4-11.

Adjusting the Front Gauge Wheels

⚠ WARNING

Keep hands and feet away from the discharge opening of the cutting deck.

The front gauge wheels on the mower deck are an anti-scalp feature, and should not ride on the ground. The front gauge wheels should be approximately 1/4-1/2" above the ground when the deck is set in the desired height setting. Using the deck lift handle, set the deck in the desired height setting, then check the gauge wheel distance from the ground below. If necessary adjust the front gauge wheels as follows:

- Visually check the distance between the front gauge wheels and the ground. If the gauge wheels are near or touching the ground, they should be raised. If more than 1/2" above the ground, they should be lowered.
- Remove the lock nut (a) securing one of the front gauge wheels (b) to the deck. Remove the front gauge wheel (b), hex screw (c) and spacer (d). See Figure 4-12.

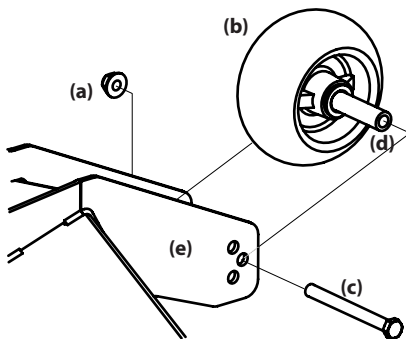

Figure 4-12

Note: There are a pair of front gauge wheels on the nose of the 54" and 60" decks.

- Insert the hex screw (c) into one of the three index holes in the front gauge wheel bracket (e) that will give the front gauge wheel (b) a 1/4-1/2" clearance with the ground.
- Note the index hole of the just adjusted front gauge wheel (b), and adjust the other front gauge wheel (b) into the respective index hole of the other front gauge wheel bracket (e).

Service

Charging the Battery

Test and, if necessary, recharge the battery after the tractor has been stored for a period of time.

Models with Lead-Acid Battery

- A voltmeter or load tester should read 12.6 volts (DC) or higher across the battery terminals. See Figure 4-13.

Voltmeter Reading	State of Charge	Charging Time
12.7	100%	Full Charge
12.4	75%	90 Min.
12.2	50%	180 Min.
12.0	25%	280 Min.

Figure 4-13

- Charge the battery with a 12-volt battery charger at a MAXIMUM rate of 10 amps.

Models with AGM Battery

- An AGM Battery charger should be used. Recommended charge rate is 1.1A/14.8V.

Note: Do NOT use an automotive charger.

- If your battery charger is automatic, charge the battery until the charger indicates that charging is complete. If the charger is not automatic, charge for no fewer than eight (8) hours.

Jump Starting

⚠ WARNING

Failure to use this starting procedure can cause sparking, and the gases in the battery to explode.

- Connect the end of one cable to the disabled machine battery's positive terminal; then connect the other end of that cable to the booster battery's positive terminal.
- Connect one end of the other cable to the booster battery's negative terminal; then connect the other end of that cable to the frame of the disabled tractor, as far from the battery as possible.
- Start the disabled tractor following the normal starting instructions previously provided; then disconnect the jumper cables in the exact reverse order of their connection.
- Have the tractor's electrical system checked and repaired as soon as possible to eliminate the need for jump starting.

Servicing Electrical System

Fuse

There are two fuses located inside the left console. Lift the seat and look down at the left console to find the location of the fuses. One 30 amp fuse for the power steering and one 25 amp fuse, the ignition, PTO, etc. These are standard plug-in type automotive fuses. Always use the same capacity fuse for replacement. Check the 30 amp fuse if the power steering is not working and check the 25 amp fuse for all other electrical problems.

If you have a recurring problem with blown fuses, have the tractor's electrical system checked by your authorized service dealer.

Safety Interlock System & Switch Operation Checks

The following operational checks should be made daily:

PTO Switch

- Sit in the operator's seat. With the drive pedals in the neutral position and the parking brake engaged, engage the PTO switch by pulling up on the knob and try to start the engine. The engine should not start. If it does, the PTO switch must be replaced. See your authorized service dealer.
- If the engine does not start, disengage the PTO by pressing the knob down and start the engine. Now engage the PTO and the blades should rotate.
- If the blades do not turn, the PTO switch must be replaced, the seat switch must be replaced or the electric PTO clutch must be repaired. See your authorized service dealer.

Parking Brake Switch

- Sit in the operator's seat. With the drive pedals in the neutral position and the PTO disengaged, release the parking brake and try to start the engine. The engine should not start.
- If it does, the parking brake switch must be repositioned or replaced. See your authorized service dealer. If the engine does not start, engage the parking brake and start the engine.

Seat Switch

- With the drive pedals in the neutral position, the parking brake engaged and the PTO disengaged, start the engine. Now release the parking brake and raise up off the seat. Release the operator's seat and the engine should stop. If the engine does not stop, the seat switch must be replaced. See your authorized service dealer.
- With the drive pedals in the neutral position, the parking brake engaged and the PTO disengaged, sit in the operator's seat and start the engine. Engage the PTO and the blades should start to rotate. Raise up slightly off the operator's seat and the blades should stop. If the blades do not stop when you dismount from the operator's seat, the seat switch must be replaced. See your authorized service dealer.

Electric PTO Clutch

- This clutch operates when the engine is running, the operator is in the operator's seat and the PTO is engaged. This electric clutch is a normally trouble free device. If a problem develops and the blades do not turn, first check the 25 amp fuse, then investigate the wiring harness and the connections to the seat switch, the PTO switch and the electric blade clutch. Then check the seat switch, the PTO switch and finally the electric blade clutch. If the PTO clutch is still not working properly, see an authorized service dealer.

Rear Tire Removal/Replacement

1. Remove the four lug nuts (a) to remove the tire. See Figure 4-14.

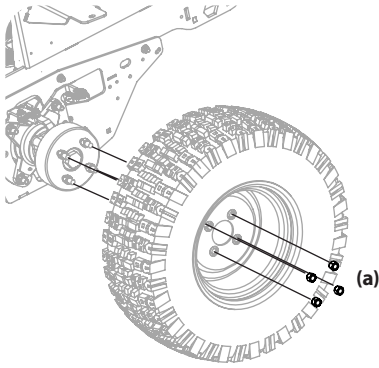

Figure 4-14

2. Reinstall the tire using the four lug nuts. See Figure 4-14. Torque the lug nuts (a) to 65-70 ft-lbs.

Front Tire Removal/Replacement

1. Remove the hex screw (a) and flange lock nut (b) that secures the front wheel (c) to the yoke assembly (d). See Figure 4-15.

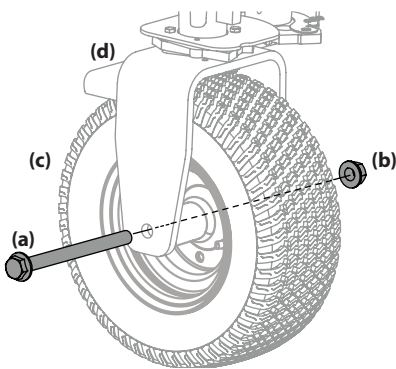

Figure 4-15

2. To re-install or replace the front tire, reverse Step 1. Tighten the hardware to 75-90 ft-lbs. See Figure 4-15.

⚠ WARNING

Do not operate the tractor without the wheel weights in place.

Deck Removal

Remove the mower deck from the tractor as follows:

1. Lower the deck to the ground. Capture the deck lift by placing the clevis pin behind the lowest position.
2. Apply the parking brake. Remove ignition key and the spark plug cap.

⚠ WARNING

The muffler and any surrounding parts at the rear of the tractor may be extremely hot, and could cause serious burns. Use extreme caution when near the muffler. Allow the muffler to fully cool before removing the belt from the PTO pulley.

3. Using a 1/2" drive in the idler pulley bracket (a), turn the wrench towards the right of the tractor and slide the PTO belt (b) off the PTO pulley (c). See Figure 4-16.

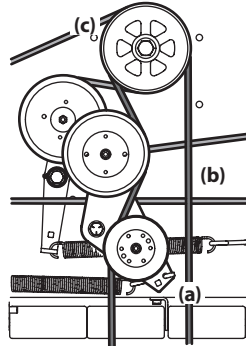

Figure 4-16

4. Remove the four lynch pins (a) that secure the deck to the deck lift assembly. See Figure 4-17.

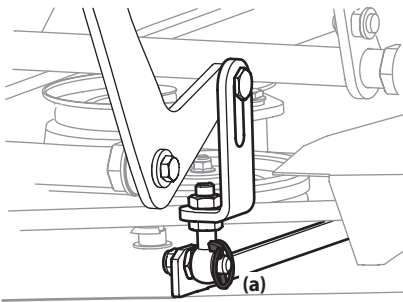

Figure 4-17

⚠ CAUTION

The spring is under tension due to the weight of the deck. When removing the lift linkage from the deck the tension of the springs will go from the deck to the deck lift pedal. Not capturing the deck lift pedal by placing the clevis pin behind the lowest position while removing the lift linkage from the deck will cause it to snap back.

5. Remove the hex screws (a) and flange lock nuts (b) securing the front deck control rods (c) to the deck. See Figure 4-18.

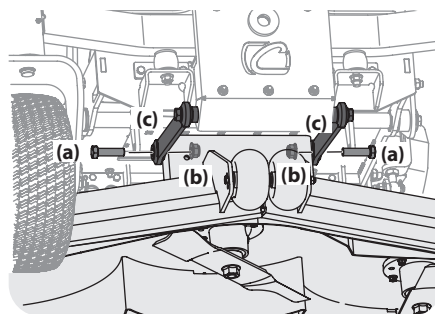

Figure 4-18

6. Turn front wheels as if to make a pivot turn.
7. Shift the deck toward the right side of the mower and remove.
8. To install reverse the process.

Replacing the PTO Belt

1. Remove the PTO belt (a) from the deck as instructed in the Deck Removal section then remove it from around the PTO clutch. See Figure 4-19.

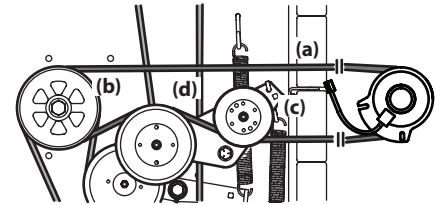

Figure 4-19

2. Route the PTO belt (a) as shown in Figure 4-19.
3. After routing the belt around the PTO pulley (b), use a 1/2" drive in the idler pulley bracket (c) and turn towards the right of the tractor to finish routing the belt around the idler pulley (d). See Figure 4-19.
4. Reinstall the deck by reversing the previous steps.

Replacing the Deck Belt

1. Set the parking brake. Remove ignition key and both spark plug caps.
2. Remove the PTO belt, (refer to Deck Removal).
3. To remove the belt covers (a), remove the wing knobs (b) from the carriage screws (c) securing it to the deck. See Figure 4-20.

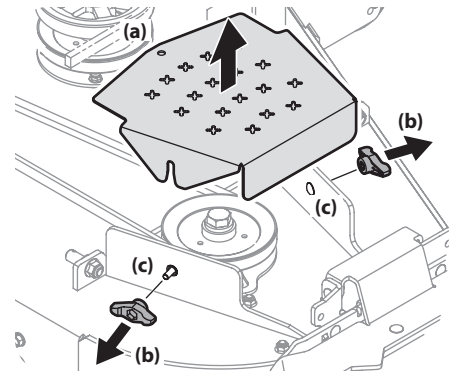

Figure 4-20

4. The speed nut should hold the carriage screw (c) and tab bolt in place, if not re-install as shown in Figure 4-20.

- Using a 1/2" drive insert the end into the 1/2" square opening in the deck idler assembly (a) and rotate the deck idler assembly (a) clockwise. See Figure 4-21. While holding the deck idler assembly (a), loosen the deck belt from the pulley and slide the belt away from the pulley.

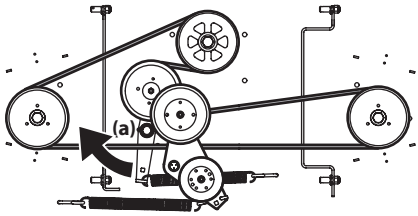

Figure 4-21

⚠ WARNING

Avoid pinching injuries. Never place your fingers on the idler spring or between the belt and a pulley while removing the belt.

- Route the new belt as shown in Figure 4-21. Then reinstall the deck and PTO belt.

Replacing the Blades

⚠ WARNING

Before performing any maintenance, disengage the PTO, engage the parking brake lever, turn the ignition key to the "OFF" position and remove the key from the switch. Protect your hands by using heavy gloves when handling the blades. When servicing the mower deck, be careful not to cut yourself on the sharpened blades.

- Remove the deck as instructed in the Deck Removal section.
- For easier access, flip the deck over, then jack up the front of the deck about one foot and block it in that position.

To remove the blade:

- Secure the blade from turning counter-clockwise during service by placing a block of wood between the blade and the deck housing, see Figure 4-22, or wrap a rag around one end of the blade and grasp the blade firmly.

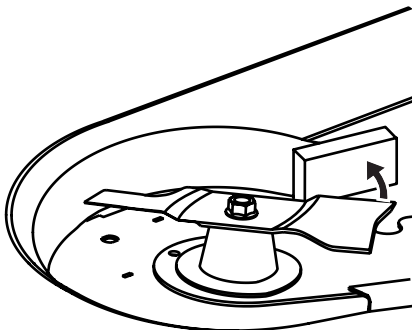

Figure 4-22

- Remove the flange lock nut (a) and flat washer (b) from the spindle shaft and remove the blade (c). See Figure 4-23.

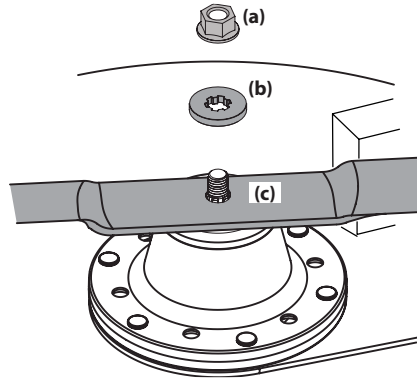

Figure 4-23

To replace or reinstall the blade:

- Put the blade in place on the spindle shaft. Be sure to install the blade with the side marked "Bottom" or "Grass Side" (or with a part number stamped in it) facing the ground when the deck is reinstalled on the tractor and in the operating position.
- Carefully place the flat washer on the spindle shaft. Be sure that the splines at the base of the spindle shaft threads line up with the washer splines. See Figure 4-24.

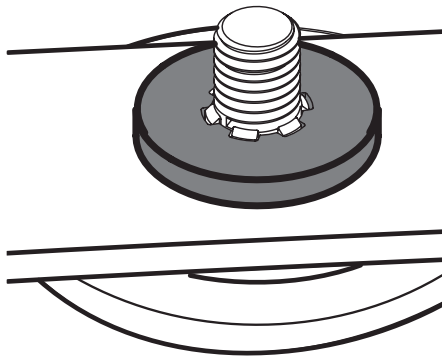

Figure 4-24

- Secure the blade from turning clockwise when reinstalling the flange lock nut (the opposite direction of blade removal).
- Install the flange lock nut onto the spindle shaft over the blade and flat washer. Torque to 100-130 ft-lbs (136-176 N-m).

⚠ WARNING

Never mow with dull blades. Blades that are bent should be replaced. The cutting blades are sharp and can cause severe injury. Wrap the cutting surface of the blade with a rag and wear heavy gloves to avoid injury.

Sharpening the Blades

- Set the parking brake.
- Clean any debris from the blades. Keep blades sharp and free of build up at all times.

- To properly sharpen the cutting blades, remove equal amounts of metal from both ends of the blades along the cutting edges, parallel to the trailing edge, at a 25°-30° angle. Always grind each cutting blade edge equally to maintain proper blade balance. See Figure 4-25.

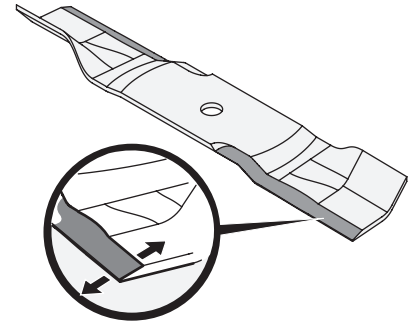

Figure 4-25

⚠ WARNING

If a blade is bent or otherwise damaged, replace the blade with a new one. Use only original equipment blades.

⚠ WARNING

A poorly balanced blade will cause excessive vibration, may damage the machine, and/or result in personal injury.

- Test the blade's balance using a blade balancer. Grind metal from the heavy side until it balances evenly.

Note: When replacing the blade, be sure to install the blade with the side marked "Bottom" or "Grass Side" (or with a part number stamped in it) facing the ground when the mower is in the operating position.

⚠ WARNING

Use a torque wrench to tighten the blade spindle hex flange nut to between 100 ft-lbs and 130 ft-lbs.

Changing the Spindle Assembly

- Remove the deck as instructed in the Deck Removal section.
- Jack up the front of the mowing deck about one foot and block it in that position.
- Remove the deck cover.
- Remove the drive belts. See Replacing the Deck belt.
- Remove the blade. See Replacing the Blades.

- Remove the hex flange bolts (a) and flat washers (b) securing the left and right spindle pulleys (c) to the spindle assembly (d). See Figure 4-26.

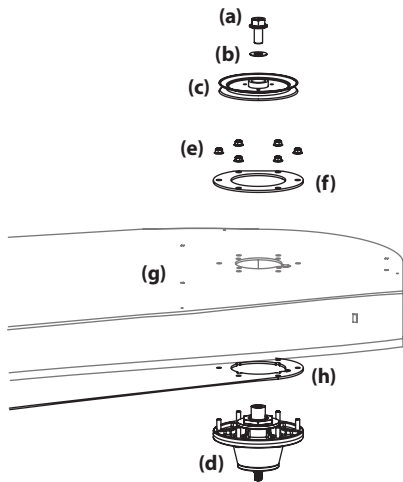

Figure 4-26

- Remove the six (6) flange lock nuts (e) securing the left and right spindle assemblies (d) and the support plates (f) to the deck shell (g). See Figure 4-26.
- Note:** The deck support plate (h) does not need to be removed unless all three spindles are being replaced.
- Remove the hex flange bolt (a) and flat washer (b) securing the drive pulley (c) and center spindle pulley (d) to the spindle assembly (e). See Figure 4-27.

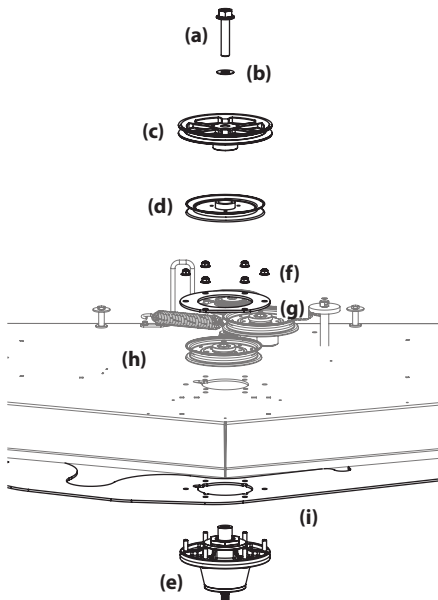

Figure 4-27

- Remove the six (6) flange lock nuts (f) securing the center (d), spindle assembly (e) and the support plates (g) to the deck shell (h). See Figure 4-27.
- Note:** The deck support plate (i) does not need to be removed unless all three spindles are being replaced.

- Reverse the process to install the spindle assembly. When installing the new spindle assembly be sure to install the hardware exactly as shown in Figure 4-26. Torque the hex flange bolts to 250 ft-lbs and the flange lock nuts to 21-32 ft-lbs.

Changing the Transmission Drive Belt

Several components must be removed and special tools used in order to change the tractor's transmission drive belt. See your authorized service dealer to have the transmission drive belt replaced.

Tractor Creeping

Creeping is the slight forward or backward movement of the mower when the throttle is on and the speed control pedals are in the neutral position. If your mower creeps, see your authorized service dealer.

Troubleshooting

Excessive vibration

- Cutting blade loose or unbalanced.
 - Tighten blade and spindle.
- Damaged or bent cutting blade.
 - Replace blade.

Uneven cut

- Deck not properly leveled.
 - Perform side-to-side deck adjustment.
- Cutting blade dull or damaged.
 - Sharpen or replace cutting blade.
- Uneven tire pressure.
 - Check and correct tire pressure in all four tires.

Mower will not mulch grass

- Engine speed too low.
 - Place throttle in FAST (rabbit) position.
- Wet grass.
 - Do not mulch when grass is wet.
- Excessively high grass.
 - Mow once at a high cutting height, then mow again at desired height or make a narrower cutting swath.
- Dull blade.
 - Sharpen or replace blade.

Engine fails to start

- PTO/Blade engaged.
 - Place blade engage lever in disengaged (OFF) position.
- Blown fuse.
 - Replace fuse(s).
- Parking brake not engaged.
 - Engage parking brake.
- See Engine Operator's Manual.

Part Number	Description
954-04327 954-04319	Deck Belt (54" Deck) Deck Belt (60/72" Decks)
954-05127 954-05128 954-05129	PTO Belt (54" Deck) PTO Belt (60" Deck) PTO Belt (72" Deck)
954-05037A	Drive Belt
942-04416 942-04415 942-05179	Hi-Lift Blade, 19.0 (54" Deck) Hi-Lift Blade, 21.0 (60" Deck) Hi-Lift Blade, 25.0 (72" Deck)
618-08473	Deck Spindle
634-05451	Deck Wheel
731-11926	Deck Skid Guard
925-1707D	Battery
751-15243	Gas Cap
946-05260	Throttle Control Cable (If equipped)
946-05341B	Choke Control (If equipped)
925-06908	Ignition Key
946-05103A	Park Brake Cable
931-05396C 931-05419	Chute Assembly (54/60" Decks) Chute Assembly (72" Deck)
634-05228 634-05193 634-05192	Rear Wheel Assembly, 24 x 12-12 (554) Rear Wheel Assembly, 24 x 12-12 (560/760) Rear Wheel Assembly, 26 x 12-12 (960/972)
634-05427 634-05428A	Front Wheel Assembly, 15 x 6-6 (500 Series) Front Wheel Assembly 16 x 6.5-6 (700 & 900 Series)
02003749	Front Axle Wear Plates, 1.125 x 5.0
741-0941A	Front Axle Ball Bearings, 1.0 x 52 x 15

Attachments & Accessories

Part Number	Description
59A30060150	Triple Bagger
59A30061150	54" Blower Kit
59A30062150	60" Blower Kit
59A30063150	54"/60" Bagger Fan
59B30037150	Front Weight Kit
19B70038100	54" Mulch Kit
19B70039100	60" Mulch Kit
59A30053150	72" Mulch Kit
490-241-0036	Rear Tire Chain Kit
59B30021150	12V Outlet Receptacle
59B30011150	Work Light Kit

Part Number	Description
59A30018150	Caster Wheel Kit
59A30057150	Ultra Traction Tire, 26 x 12-12
59A30058150	Ultra Traction Tire, 24 x 12-12
59C30052150	Heavy Duty Striping Roller †
490-850-0008	Oil Siphon
490-850-0005	Blade Removal Tool
490-325-0020	Tire Sealant
490-900-0045	Oil Filter Wrench
490-900-0062	Armortek Non-Stick Spray
490-000-0028	Carburetor & Choke Cleaner

† - 500 Series Only. Feature comes standard on 700, 900 models.

MTD Product Warranty

1. Statutory Warranty

- 1.1 If you are a “consumer” pursuant to the Australian Consumer Law, then MTD Products Australia Pty Ltd ACN 004 873 572 (**MTD**) confirms the following: *Our goods come with guarantees that cannot be excluded under the Australian Consumer Law. You are entitled to a replacement or refund for a major failure and for compensation for any other reasonably foreseeable loss or damage. You are also entitled to have the goods repaired or replaced if the goods fail to be of acceptable quality and the failure does not amount to a major failure.*
- 1.2 Your right to replacement, refund or compensation under the Australian Consumer Law may be against MTD and/or the party that supplied the relevant product to you, as specified in the Australian Consumer Law.
- 1.3 The benefits provided to you by this Warranty are in addition to other rights and remedies available to you under the law.

2. Contractual Warranty

- 2.1 In addition to the rights and remedies you have under law :

MTD Products Australia Pty Ltd
of 6-8 Zenith Road, Dandenong South, Victoria 3175
Email: enquiries@mtdproducts.com
Telephone: 1300 951 594

provides the following additional contractual warranty in support of the products listed in Table A (**MTD Product**), supplied by MTD or an authorised MTD dealer within Australia to you.

- 2.2 Subject to the terms and conditions of the warranty set out in this document (**Warranty**), MTD warrants that the MTD Product will be free from defects in materials and workmanship for the period set out in Table A below (**Warranty Period**).
- 2.3 The Warranty Period will commence on the date you purchase the MTD Product from MTD or an MTD dealer. The Warranty Period varies, as set out in the Table A, according to:
- (a) the type of MTD Product;
 - (b) the part of the MTD Product that is defective; and
 - (c) whether the MTD Product is:
 - (i) solely used for personal and domestic purposes, which excludes any use in connection with a business or trade (**Residential Use**); or
 - (ii) not solely used for personal and domestic purposes, or is used in connection with a business or trade (**Commercial Use**).

TABLE A

LAWN MOWERS	General Warranty Period Domestic Use	General Warranty Period Commercial	Engine Warranty Period	Attachments Warranty Period
	Excludes engine, attachments and normal wear parts			
Rover Steel Deck / Rover Engine/Endeavor	2 Years	90 Days	5 Year Domestic / 90 Day Commercial	N/A
Steel Deck / Non-Rover Engine	2 Years	90 Days	2 Year Domestic / 90 Day Commercial	Nil
Rover Steel Deck / Rover Engine	5 Years	90 Days	5 Year Domestic / 90 Day Commercial	N/A
Rover Steel Deck / Non-Rover Engine	5 Years	90 Days	2 Year Domestic / 90 Day Commercial	N/A
Rover Alloy Deck / Rover Engine	5 Years	90 Days	5 Year Domestic / 90 Day Commercial	N/A
Rover Alloy Deck / Non-Rover Engine	5 Years	90 Days	2 Year Domestic / 90 Day Commercial	N/A
Cylinder Mowers / Petrol	5 Years	Nil	2 Year Domestic / 90 Day Commercial	1 Year Domestic / 90 Day Commercial
Cylinder Mowers / Battery	2 Years	Nil	2 Year Domestic / 90 Day Commercial	1 Year Domestic / 90 Day Commercial
HANDHELD EQUIPMENT	General Warranty Period Domestic Use	General Warranty Period Commercial	Engine Warranty Period	Attachments Warranty Period
	Excludes engine, attachments and normal wear parts			
Line Trimmers	2 Years	90 Days	2 Year Domestic / 90 Day Commercial	1 Year Domestic / 90 Day Commercial
Blowers	2 Years	90 Days	2 Year Domestic / 90 Day Commercial	1 Year Domestic / 90 Day Commercial
Chainsaws	2 Years	90 Days	2 Year Domestic / 90 Day Commercial	1 Year Domestic / 90 Day Commercial
Hedge Trimmer	2 Years	90 Days	2 Year Domestic / 90 Day Commercial	1 Year Domestic / 90 Day Commercial
Edger	2 Years	90 Days	2 Year Domestic / 90 Day Commercial	N/A
Rover Edger	5 Years	90 Days	2 Year Domestic / 90 Day Commercial	N/A
Rover Powered by CORE	General Warranty Period Domestic Use	General Warranty Period Commercial	Charger & Battery Warranty Period	Attachments Warranty Period
	Excludes motor, attachments and normal wear parts			
Rover CORE Powered Product	5 Years	90 Days	3 Years Domestic / 90 Day Commercial	N/A
SEASONAL	General Warranty Period Domestic Use	General Warranty Period Commercial	Engine Warranty Period	Attachments Warranty Period
	Excludes engine, attachments and normal wear parts			
Log Splitter	2 Years	90 Days	2 Year Domestic / 90 Day Commercial	N/A
Rover Log Splitters Rover Engine	5 Years	90 Days	5 Year Domestic / 90 Day Commercial	N/A
Rover Log Splitters Non-Rover Engine	5 Years	90 Days	2 Year Domestic / 90 Day Commercial	N/A
Chipper Shredders	2 Years	90 Days	2 Year Domestic / 90 Day Commercial	N/A
Rover Chipper Shredders	5 Years	90 Days	2 Year Domestic / 90 Day Commercial	N/A
Chipper Shredder Vacs	2 Years	90 Days	2 Year Domestic / 90 Day Commercial	N/A
Rover Chipper Shredder Vacs Rover Engine	5 Years	90 Days	5 Year Domestic / 90 Day Commercial	N/A
Rover Chipper Shredder Vacs Non-Rover Engine	5 Years	90 Days	2 Year Domestic / 90 Day Commercial	N/A
Tillers	2 Years	90 Days	2 Year Domestic / 90 Day Commercial	N/A
Rover Tillers Rover Engine	5 Years	90 Days	5 Year Domestic / 90 Day Commercial	N/A
Rover Tillers Non-Rover Engine	5 Years	90 Days	2 Year Domestic / 90 Day Commercial	N/A
Wheeled String Trimmer	2 Years	90 Days	2 Year Domestic / 90 Day Commercial	N/A

TABLE A CONTINUED

ROVER RIDE ONS & ZERO- TURNS	General Warranty Period Domestic Use	General Warranty Period Commercial Use	Engine Warranty Period	Attachments Warranty Period
	Excludes engine, attachments and normal wear parts			
Micro Rider 24"	2 Years	90 Days	2 Year Domestic / 90 Day Commercial	1 Year Domestic / 90 Day Commercial
Rover Micro Rider 24"	5 Years	90 Days	2 Year Domestic / 90 Day Commercial	1 Year Domestic / 90 Day Commercial
Mini Rider 30"	2 Years	90 Days	2 Year Domestic / 90 Day Commercial	1 Year Domestic / 90 Day Commercial
Rover Mini Rider 30"	5 Years	90 Days	5 Year Domestic / 90 Day Commercial	1 Year Domestic / 90 Day Commercial
Rover Mini Rider 30"Hydrostatic Transmission	5 Years	90 Days	5 Year Domestic / 90 Day Commercial	1 Year Domestic / 90 Day Commercial
439/38	5 Years	90 Days	5 Year Domestic / 90 Day Commercial	1 Year Domestic / 90 Day Commercial
Rover 420/38	5 Years	90 Days	5 Year Domestic / 90 Day Commercial	1 Year Domestic / 90 Day Commercial
Rover Rancher 547/38	5 Years	90 Days	5 Year Domestic / 90 Day Commercial	1 Year Domestic / 90 Day Commercial
Rover Raider 17/42	5 Years	90 Days	2 Year Domestic / 90 Day Commercial	1 Year Domestic / 90 Day Commercial
Rover Rancher 547/42	5 Years	90 Days	5 Year Domestic / 90 Day Commercial	1 Year Domestic / 90 Day Commercial
Rover Lawn King 547/42	5 Years	90 Days	5 Year Domestic / 90 Day Commercial	1 Year Domestic / 90 Day Commercial
Rover Lawn King 18/42 Kawasaki	5 Years	90 Days	5 Year Domestic / 90 Day Commercial	1 Year Domestic / 90 Day Commercial
Rover Lawn King 24/42 Kawasaki	5 Years	90 Days	5 Year Domestic / 90 Day Commercial	1 Year Domestic / 90 Day Commercial
Rover RZT L 34	5 Years	90 Days	5 Year Domestic / 90 Day Commercial	1 Year Domestic / 90 Day Commercial
Rover RZT L 42 Kohler	5 Years	90 Days	3 Year Domestic / 90 Day Commercial	1 Year Domestic / 90 Day Commercial
Rover RZT L 46 Kawasaki	5 Years	90 Days	2 Year Domestic / 90 Day Commercial	1 Year Domestic / 90 Day Commercial
Rover RZT S 46 Kohler	5 Years	90 Days	3 Year Domestic / 90 Day Commercial	1 Year Domestic / 90 Day Commercial
Rover RZ L 42 679cc	5 Years	90 Days	5 Year Domestic / 90 Day Commercial	1 Year Domestic / 90 Day Commercial
Rover RZT 50 Kohler	5 Years	90 Days	3 Year Domestic / 90 Day Commercial	1 Year Domestic / 90 Day Commercial
	5 Year fabricated deck shell.			
Rover RZ L 46 Kawasaki	5 Years	90 Days	3 Year Domestic / 90 Day Commercial	1 Year Domestic / 90 Day Commercial
	5 Year fabricated deck shell.			

TABLE A CONTINUED

CUB CADET RIDE ONS & ZERO-TURNS	General Warranty Period Domestic Use	General Warranty Period Commercial Use	Engine Warranty Period	Attachment Warranty Period
	Excludes engine, attachments and normal wear parts			
CC30 e (Electric Rider)	3 Years	90 Days	N/A	1 Year Domestic / Nil Commercial
LT42 e (Electric Rider)	3 Years	90 Days	N/A	1 Year Domestic / Nil Commercial
LX 42 Kohler	6 Years	90 Days	6 Year Domestic / 90 Day Commercial	1 Year Domestic / Nil Commercial
LX 42 EFI Cub Cadet	6 Years	90 Days	6 Year Domestic / 90 Day Commercial	1 Year Domestic / Nil Commercial
LX 46 Kohler	6 Years	90 Days	6 Year Domestic / 90 Day Commercial	1 Year Domestic / Nil Commercial
LX 54 Kohler	6 Years	90 Days	6 Year Domestic / 90 Day Commercial	1 Year Domestic / Nil Commercial
RZT L 42 Kohler	6 Years	90 Days	6 Year Domestic / 90 Day Commercial	1 Year Domestic / Nil Commercial
RZT S 42 Kohler	6 Years	90 Days	6 Year Domestic / 90 Day Commercial	1 Year Domestic / Nil Commercial
RZT L 50 Kohler	6 Years	90 Days	6 Year Domestic / 90 Day Commercial	1 Year Domestic / Nil Commercial
RZT S 50 Kohler	6 Years	90 Days	6 Year Domestic / 90 Day Commercial	1 Year Domestic / Nil Commercial
RZT S 46 Kohler	6 Years.	90 Days	6 Year Domestic / 90 Day Commercial	1 Year Domestic / Nil Commercial
ZT2 L 54 Kawasaki	3 Years.	90 Days	3 Year Domestic / 90 Day Commercial	1 Year Domestic / Nil Commercial
	5 Year fabricated deck shell.			
Z-Force LZ 54 Kohler	3 Years.	1 Year	3 Year Domestic / 90 Day Commercial	1 Year Domestic / Nil Commercial
	5 Year fabricated deck shell.			
Z-Force LX 48 Kohler	3 Years.	1 Year	3 Year Domestic / 1 Year Commercial	1 Year Domestic / Nil Commercial
	5 Year fabricated deck shell.			
Z-Force SX 48 Kohler	3 Years.	1 Year	3 Year Domestic / 1 Year Commercial	1 Year Domestic / Nil Commercial
	5 Year fabricated deck shell.			
Z-Force LX 60 Kohler	3 Years.	1 Year	3 Year Domestic / 1 Year Commercial	1 Year Domestic / Nil Commercial
	5 Year fabricated deck shell.			
Z-Force SX Kawasaki Models	3 Years.	2 Years	3 Year Domestic / 2 Year Commercial	1 Year Domestic / Nil Commercial
	5 Year fabricated deck shell.			
ZTX5 Kawasaki Models	3 Years.	2 Years	3 Year Domestic / 2 Year Commercial	1 Year Domestic / Nil Commercial
	5 Year fabricated deck shell.			

TABLE A CONTINUED

CUB CADET COMMERCIAL	General Warranty Period Domestic Use	General Warranty Period Commercial Use	Engine Warranty Period	Attachments Warranty Period
	Excludes engine, attachments and normal wear parts			
Handheld	3 Years	1 year	1 year	N/A
Brush Cutter	3 Years	1 year	1 year	N/A
Hedge Trimmer	3 Years	1 year	1 year	N/A
CUB CADET COMMERCIAL PRO Z	General Warranty Period Domestic Use	General Warranty Period Commercial Use	Engine Warranty Period	Attachments Warranty Period
	Excludes engine, attachments and normal wear parts			
PRO Z 148 S	3 Years.	2 Years	3 Year Domestic / 3 Year Commercial	1 Year Domestic / Nil Commercial
	5 Year fabricated deck shell.			
PRO Z 154 L	3 Years.	2 Years	3 Year Domestic / 3 Year Commercial	1 Year Domestic / Nil Commercial
	5 Year fabricated deck shell.			
PRO Z 154 S	3 Years.	2 Years	3 Year Domestic / 3 Year Commercial	1 Year Domestic / Nil Commercial
	5 Year fabricated deck shell.			
PRO Z 554 S	3 Years.	3 Years	3 Year Domestic / 3 Year Commercial	1 Year Domestic / Nil Commercial
	5 Year fabricated deck shell.			
PRO Z 760 L	3 Years.	3 Years	3 Year Domestic / 3 Year Commercial	1 Year Domestic / Nil Commercial
	5 Year fabricated deck shell.			
PRO Z 760 L	3 Years.	3 Years	3 Year Domestic / 3 Year Commercial	1 Year Domestic / Nil Commercial
	5 Year fabricated deck shell.			
PRO Z 760 S	3 Years.	3 Years	3 Year Domestic / 3 Year Commercial	1 Year Domestic / Nil Commercial
	5 Year fabricated deck shell.			
PRO Z 972 S	3 Years.	3 Years	3 Year Domestic / 3 Year Commercial	1 Year Domestic / Nil Commercial
	5 Year fabricated deck shell.			
PRO Z 972 SD & SDL	3 Years.	3 Years	3 Year Domestic / 3 Year Commercial	1 Year Domestic / Nil Commercial
	5 Year fabricated deck shell.			
Pro HW300 Hydro Walk Kawasaki	3 Years.	2 Years	3 Year Domestic / 3 Year Commercial	1 Year Domestic / Nil Commercial
	5 Year fabricated deck shell.			
Pro X 648 Kawasaki	3 Years	2 Years	3 Year Domestic / 3 Year Commercial	1 Year Domestic / Nil Commercial
	5 Year fabricated deck shell.			

TABLE A CONTINUED

WOLF- Garten	General Warranty Period Domestic & Commercial Use	Engine Warranty Period	Attachments Warranty Period
WOLF-Garten multi-Star® unit system, multi-star® Minis and the multi-star® tree care without ladder	Lifetime	NA	NA
Hand tools and all manually controlled trimmers	10 years	NA	NA

2.4 For the purpose of Table A:

- (a) “*Attachments*” means any component of a product that is not a supplied as a standard component (i.e. it is purchased separately)
- (b) Where a primary or secondary school purchases an MTD Product for use by that school, that use will be classified as Residential Use;
- (c) Honda, Briggs & Stratton and Kohler & Kawasaki engines are “*NonRover*” engines;
- (d) Normal Wear Parts include batteries, blades, blade bolts, V-belts, line heads, spark plugs and filters, as classified by MTD; and
- (e) “*rolling chassis*” means the frame plus the "running gear" like handle bars, wheels, driveshaft and axle.

2.5 In the event of dispute, MTD will determine whether the MTD Product was used for a Residential Use or Commercial Use.

3. Exclusions and limitations

3.1 The Warranty ceases to apply to any MTD Product if it is:

- (a) serviced or repaired using non-genuine parts (being parts or components not originally manufactured or imported into Australia by MTD); or
- (b) assembled, serviced, modified or adjusted by a person not appropriately trained in the assembly, servicing, modification or adjustment of the MTD Product, as determined by MTD.

3.2 This Warranty does not apply to, or in any way cover:

- (a) normal wear and tear;
- (b) defects in or related to the battery;
- (c) any defect that was brought to your attention, or would reasonably have been revealed to you if you had conducted an examination, before acquiring the MTD Product;
- (d) any defect in, or defect caused by, parts or components that were not:
 - (i) manufactured or imported into Australia by MTD;

- (ii) supplied by a supplier approved by MTD; or
- (iii) approved by MTD for use with the MTD Product;
- (e) any failure arising from accident, abuse, act of God, fire, sabotage, vandalism, contaminated fluids or neglect or failure to operate, store and/or maintain and service the MTD Product in accordance with the instruction manual supplied with the MTD Product;
- (f) any parts or services required for the normal and regular maintenance of the MTD Product e.g. lubricants;
- (g) normal adjustments which are noted in the instruction manual supplied with the MTD Product;
- (h) any defect caused by the engine being turned other than in accordance with the instruction manual supplied with the MTD Product;
- (i) any alleged defect in the MTD Product that MTD or an authorised MTD dealer cannot establish after testing and inspection;
- (j) any MTD Product that has been used other than for the purpose for which it was designed;
- (k) any MTD Product that has been overloaded or involved in an accident; or
- (l) any defect arising from the use of:
 - (i) fuel or fuel and oil mix for the engine;
 - (ii) chain and bar oil for the oil pump; or
 - (iii) lubricating oil in a four-stroke engine;

in the MTD Product other than in accordance with the instruction manual supplied with the MTD Product.

3.3 This Warranty:

- (a) is not transferable; and
- (b) does not apply to an MTD Product acquired by way of auction, or online, or from a person other than MTD or an authorised MTD dealer.

3.4 This warranty does not cover the cost of claiming under the warranty, including any freight or delivery costs. Such costs must be paid by you.

3.5 Despite any other provision of this Warranty, MTD's liability arising from, under or in connection with this Warranty is limited as set out in paragraph 5.1. Except as expressly set out in paragraph 5 and subject to law, MTD is not liable under this Warranty for any damages, losses, costs or expenses including, without limitation, loss of profit, loss of production or any financial or economic loss, and other indirect or consequential loss, which may be suffered by you or by any third party arising out of or in any way connected with any defect in an MTD Product.

3.6 Except to the extent expressly set out in this warranty, and subject to law, MTD does not make any promise or representation as to the quality, performance, or freedom from defects, of any MTD Product.

4. How to claim

4.1 To make a claim under this Warranty you must promptly, and at your own expense, take your:

- (a) MTD Product;
- (b) proof of purchase with purchase date;
- (c) evidence of warranty registration; and
- (d) full details of the alleged MTD Product defect.

to an authorised MTD dealer upon discovery of any defect in the MTD Product, and within the relevant Warranty Period. Your nearest MTD dealer can be found at cubcadet.com.au, rover.com.au or mtd.com.au. You must also provide your name, address and phone number to the MTD dealer to whom you return the MTD Product.

4.2 If you have any inquiries about making a claim, please contact the MTD dealer from whom you purchased your MTD Product or your nearest MTD dealer.

5. MTD's Obligations

5.1 The obligations of MTD under this warranty will be limited to one of the following at the election of MTD:

- (a) repair of the MTD Product;
- (b) provision of a replacement MTD Product; or
- (c) a refund of the price you paid for the MTD Product.

5.2 MTD reserves the right to replace the defective parts or components of an MTD Product with parts and components of similar quality, grade and composition where an identical part or component is not available.